

West Tisbury (also will be installed on Church St., Edgartown)

- ▶ West Tisbury was selected because 5 routes serve the town
- ▶ Necessary Equipment Upgrades:
 - ▶ Upsize current transformer
 - ▶ New Inductive charger cabinet, 1 -300kW cabinet for two, 2-pad charging pads
 - ▶ New Switchgear 11' x 4'
 - ▶ New DAS Pad 4' x 4' – location somewhat flexible (inside could be considered)
 - ▶ Necessary Equipment Upgrades
- ▶ Future Potential Equipment Upgrades:
 - ▶ Battery Storage System (size and location – TBD)
 - ▶ Microgrid – no additional exterior infrastructure, except small cabinets installed on DAS pad



Eversource will replace the existing transformer with a larger one. We don't expect the larger transformer to be any bigger than this one, which is 76"Wx67Dx74.5"H

4

3

2

1

REVISIONS			
ZONE	REV.	DESCRIPTION	DATE

PRELIMINARY

B

B

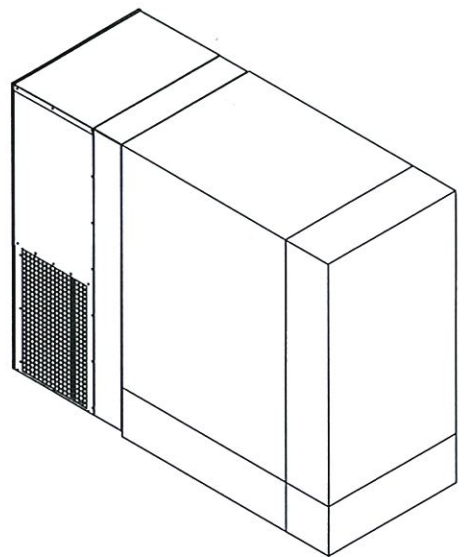
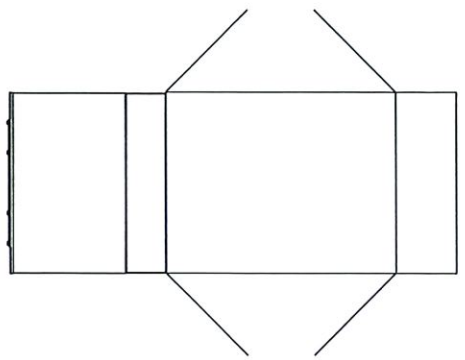

A

A

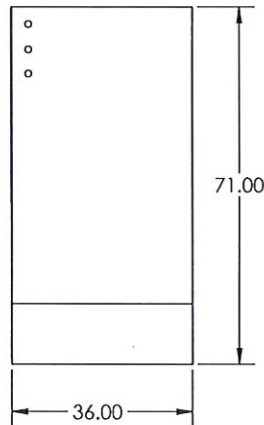
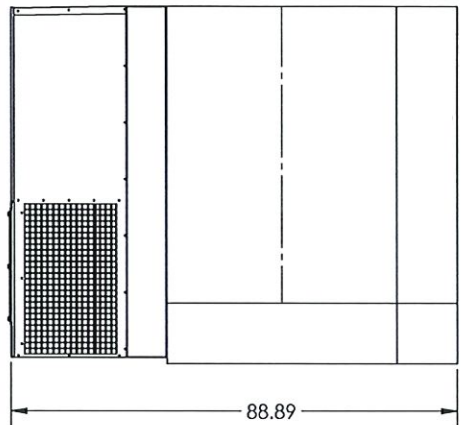

TOLERANCES (UNLESS OTHERWISE SPECIFIED)	NAME DRAWN	DATE 11/11/11		Momentum Dynamics
--	---------------	------------------	--	--------------------------

1-300kW cabinet installed in WT, within 75' of the bus stop-one cabinet for two chargers

4

3

2

PRELIMINARY



1-300kW cabinet installed in WT, within 75' of the bus stop-one cabinet for two chargers

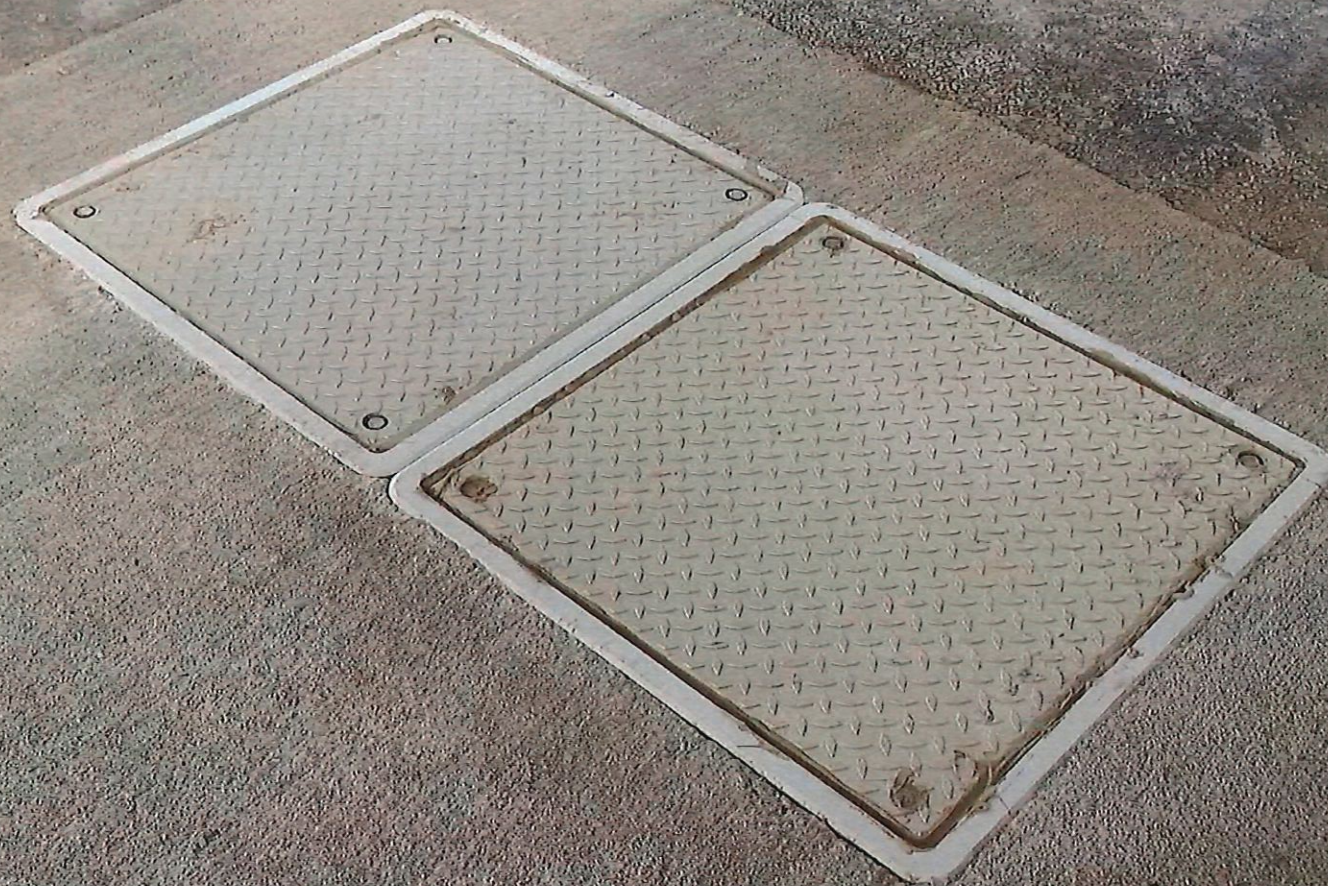

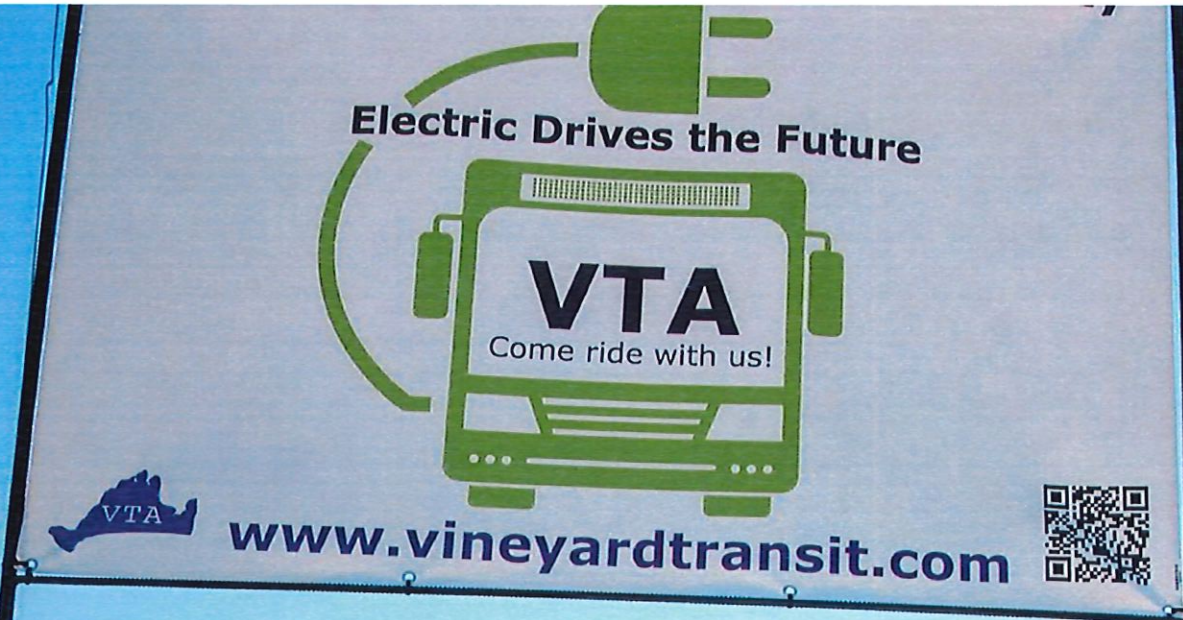

**2- 150kW charging pads, fed from 1-300kW cabinet-
this is one set, we need 2 sets**



Electric Drives the Future

VTA
Come ride with us!

www.vineyardtransit.com



Switchgear/Switchboard Pad 11'x5'
The cabinets are a slightly smaller footprint than the pad and are 91" tall

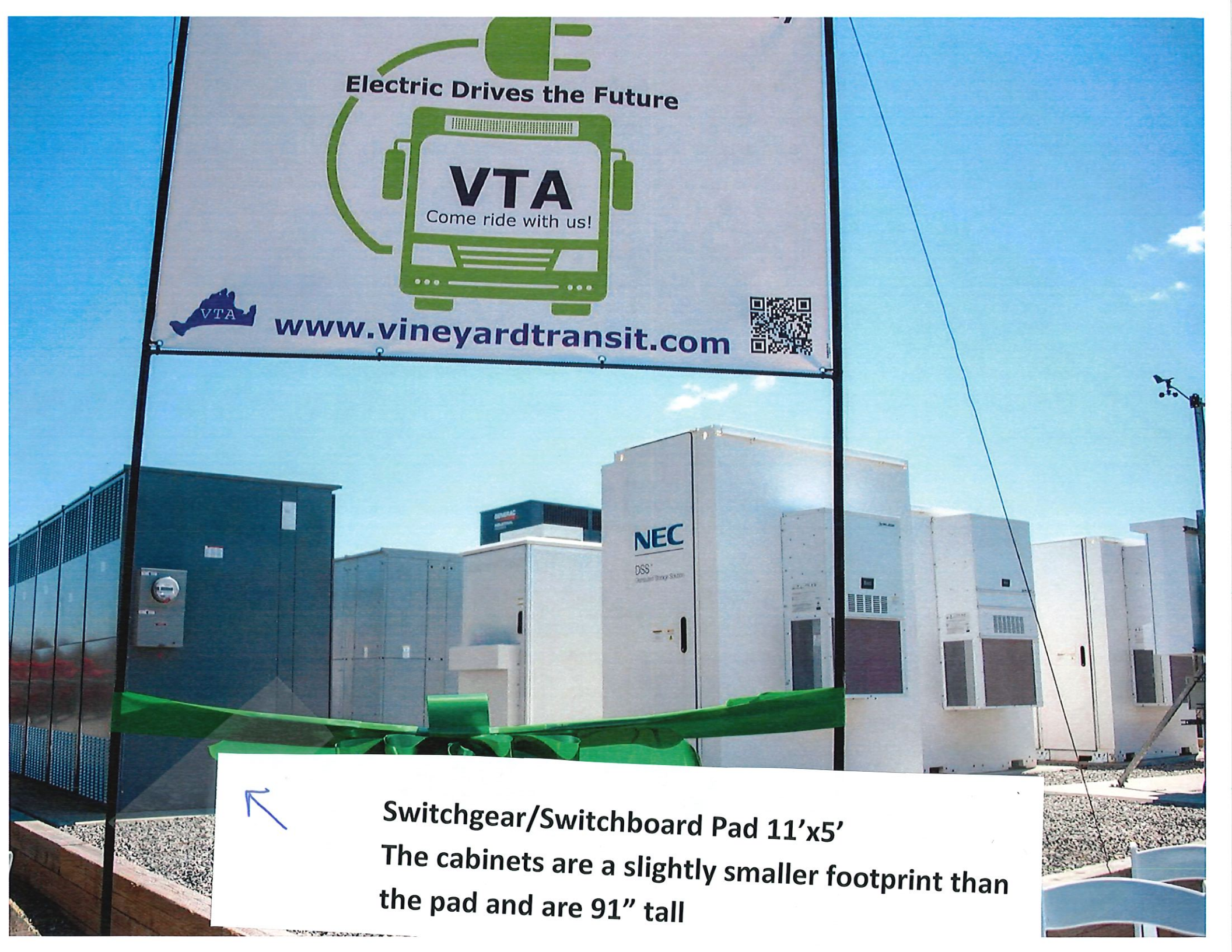

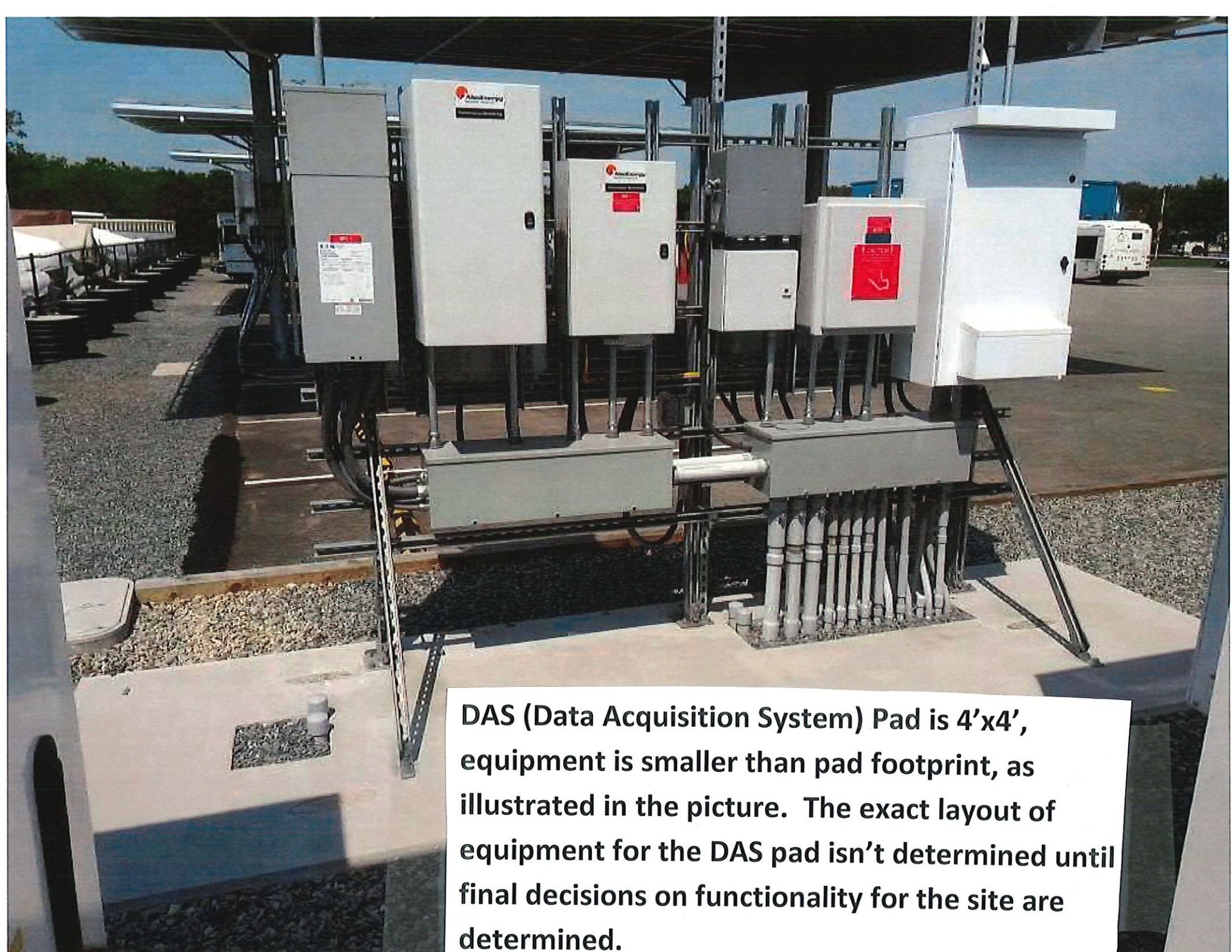

DAS (Data Acquisition System) Pad is 4'x4', equipment is smaller than pad footprint, as illustrated in the picture. The exact layout of equipment for the DAS pad isn't determined until final decisions on functionality for the site are determined.