

Lee Residence

CLIENT Mitchell & Danielle Lee e: mitch_d_lee@hotmail.com p: 646.483.9368	DESIGNER Quarters Design+Build, LLC c/o Robert Piper-Roche PO Box 2318 Vineyard Haven MA 02568 p: 617.671.5738 e: robpiperroche@gmail.com	CONTRACTOR TBD p: - e: -	ZONING INFORMATION PROJECT ADDRESS 108 & 120 Pond Road West Tisbury MA 02575 ZONING RU ASSESSOR'S MAP/PARCEL # 30.2.14 & 30.2.15
---	---	--	---

ABBREVIATIONS

ACT Acoustical Ceiling Tile	FT Foot	RO Rough Opening
ADDN Additional	FTG Footing	S&R Shelf & Rod
ADJ Adjacent	FX Fixed	SAG Supply Air Grill
ADJUST Adjustable	GA Gauge	SC Solid Core
AFF Above Finish Floor	GALV Galvanized	SCHED Schedule
AL Aluminum	GWB Gypsum Wallboard	SCR Screen
ALT Alternate	H High	SECT Section
AP Access Panel	HB Hose Bib	SH Single Hung
APP Appliance	HC Hollow Core	SIM Similar
APPROX Approximate	HCAP Handicap	SL Slider
ARCHT Architect	HDWD Hardwood	SSTL Stainless Steel
AWN Awning	HM Hollow Metal	ST Stucco
BC Brick Course	HORIZ Horizontal	STD Standard
BD Board	HOP Hopper	STL Steel
BDBD Beadboard	HT Height	STN Stone
B/O Bottom of	HTR Heater	STRUCT Structural
BM Beam	INCAN Incandescent	T Thread
BSMT Basement	INSUL Insulated	T&G Tongue & Groove
CANT Cantilever	INT Interior	TBD To Be Determined
CBB Cementitious Backer Board	IR Impact Resistant	TE Tempered
CBNT Cabinet	JT Joint	T/O Top Of
CI Cast Iron	L Low	TYP Typical
CJ Control Joint	LIN Linoleum	UNF Unfinished
CL Center Line	LKG Looking	UNO Unless Noted Otherwise
CLG Ceiling	LT Light	U/S Underside
CLR Clear	LV Low Voltage	VCB Vinyl Cove Base
CMU Concrete Masonry Unit	LVL Laminated Veneer Lumber	VCT Vinyl Composition Tile
COL Column	MATL Material	VERT Vertical
CONC Concrete	MAX Maximum	VIF Verify in Field
CONT Continuous	MDO Medium Density Overlay	VTR Vent Through Roof
CONTR Contractor	MIN Minimum	W/ With
CPT Carpet	MFGFR Manufacturer	WD Wood
CSMT Casement	MLDG Moulding	WDW Window
CT Ceramic Tile	MO Masonry Opening	WG Wire Glass
DEMO Demolition	MTD Mounted	WH Water Heater
DBL Double	MTL Metal	WP Wall Paper
DED Dedicated	N/A Not Applicable	WWF Welded Wire Fabric
DF Drinking Fountain	NIC Not in Contract	
DH Double Hung	NTS Not to Scale	
DIA Diameter	O/A Overall	
DIM[S] Dimension[s]	O/C On Center	
DN Down	OPNG Opening	
DTL[S] Detail[s]	OPP Opposite Hand	
DWG[S] Drawing[s]	OPER Operable	
EA Each	PAF Powder Actuated Fastener	
EJ Expansion Joint	PL Plate	
ELEC Electrical	PLAM Plastic Laminate	
ENG Engineered	PLST Plaster	
EQ Equal, Equivalent	PLYWD Plywood	
EXG Existing	PNT[D] Painted[ed]	
EXP Expansion	PR Pair	
EXT Exterior	PSL Parallel Strand Lumber	
FD Floor Drain	PT Pressure Treated	
FDN Foundation	R Riser	
FE[C] Fire Extinguisher [Cabinet]	RAD Radius	
FEN Fence	RAG Return Air Grill	
FF Filter Fabric	RCP Reflected Ceiling Plan	
FIN Finish	RECP Receptacle	
FLR Floor	REF Refrigerator	
FLUOR Fluorescent	RES Resilient	
FP Fireplace	REQD Required	

GENERAL NOTES

IN CASE OF CONFLICT BETWEEN DRAWINGS AND SPECIFICATIONS, THE MORE STRINGENT REQUIREMENTS GOVERN.

SECTIONS AND DETAILS SHOWN, WHILE DRAWN FOR SPECIFIC LOCATIONS ARE INTENDED TO ESTABLISH THE GENERAL TYPES OF DETAILS TO BE USED THROUGHOUT. WORK NOT INDICATED ON A PART OF THE DRAWINGS BUT REASONABLY IMPLIED TO BE SIMILAR TO THAT SHOWN AT CORRESPONDING PLACES, SHALL BE REPEATED.

CONTRACTOR TO VERIFY AND/OR ESTABLISH ALL EXISTING CONDITIONS AND DIMENSIONS AT THE SITE AND TO NOTIFY OWNER/DESIGNER OF ANY DISCREPANCIES AND/OR DEVIATIONS FROM DRAWINGS. PROPOSED REMEDIES, IF REQUIRING ADDITIONAL WORK, ARE TO BE SUBMITTED FOR APPROVAL IN THE FORM OF WRITTEN CHANGE ORDERS TO THE OWNER IN ACCORDANCE WITH THE TERMS OF THE CONTRACT BEFORE ORDERING MATERIAL OR COMMENCING WITH WORK.

WRITTEN DIMENSIONS HAVE PRECEDENCE OVER SCALED DIMENSIONS.

ALL DIMENSION TO PROPOSED CONSTRUCTION ARE TO ROUGH FRAMING, UNLESS NOTED OTHERWISE.

MECHANICAL, ELECTRICAL, PLUMBING AND FIRE PROTECTION SYSTEM ARE INDICATED ON ARCHITECTURAL DRAWINGS FOR COORDINATION ONLY.

DRAWINGS ARE FOR PERMITTING ONLY. HAVE NOT BEEN REVIEWED OR STAMPED BY A LICENSED ARCHITECT/PROFESSIONAL ENGINEER.

THIS IS A WORK FOR HIRE.

SYMBOLS

	DOOR TAG
	WINDOW TAG
	ROOM NAME
	EXTERIOR ELEVATION
	INTERIOR ELEVATION
	SECTION CUT
	DETAIL
	DETAIL
	REVISION
	VERTICAL ELEVATION
	EXISTING TOPOGRAPHIC ELEVATION
	SLOPE

LINE TYPES

	HIDDEN ITEM
	ITEM ABOVE
	CENTER LINE
	DIMENSION

**PRICING DRAWINGS
NOT FOR CONSTRUCTION**

CLIENT: Quarters Design+Build, LLC
PO Box 2318
Vineyard Haven
MA 02568
617.671.5738
robpiperroche@gmail.com

CLIENT: Mitchell & Danielle Lee
NJ

PROJECT ADDRESS: 108 & 120 Pond Road
West Tisbury
MA 02575

PROJECT NO: Q21114
PROJECT: Lee Residence

DRAWN BY: RPR
SHEET: General Information

2021.11.02

G

001

SHEET 1 OF 21

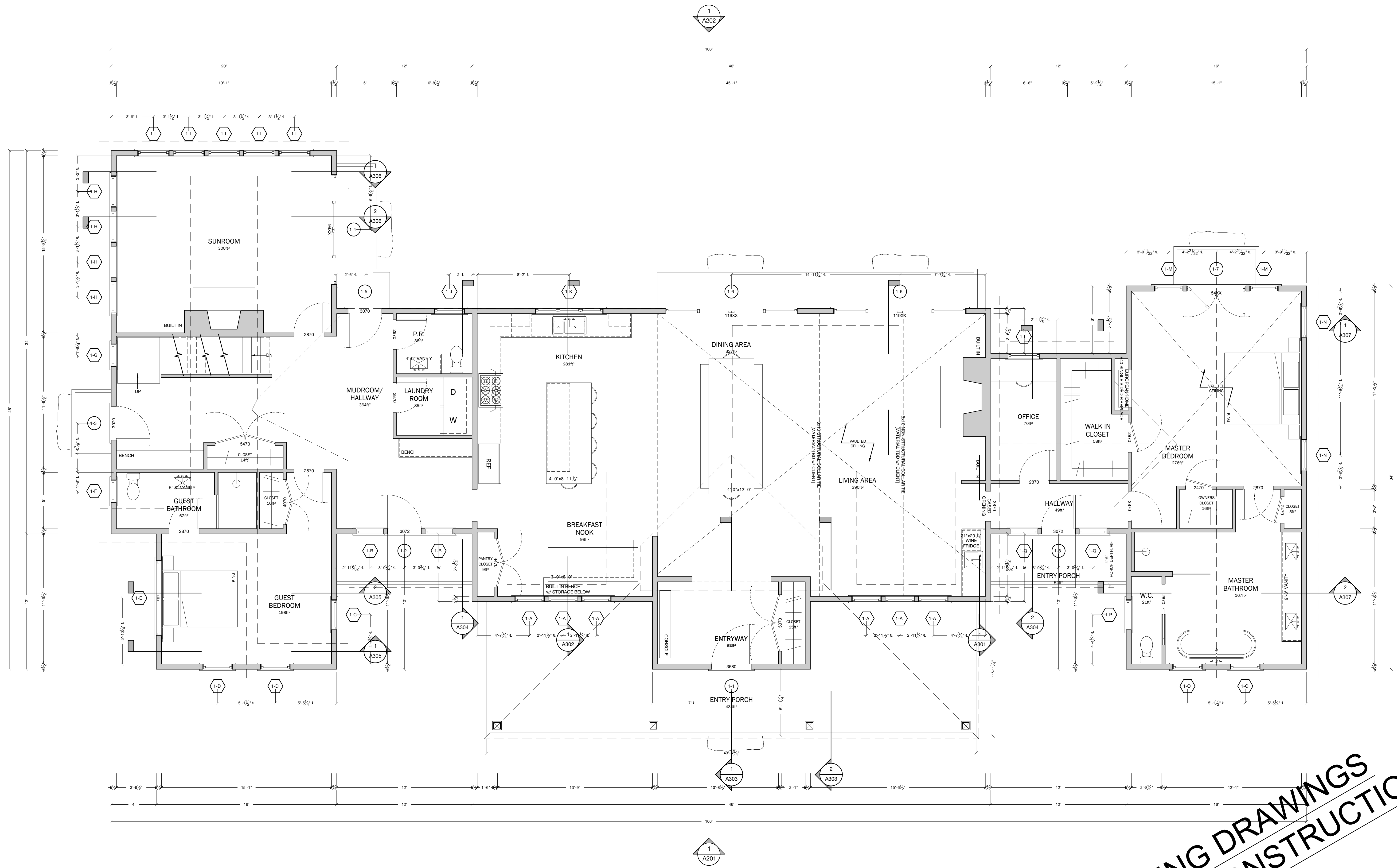

FIRST FLOOR PLAN
 1/4" = 1'-0"
 3,100R²

**PRICING DRAWINGS
 NOT FOR CONSTRUCTION**

Quarters Design+Build, LLC
 P.O. Box 2318
 Vineyard Haven
 MA 02568
 617.671.5798
 robbiparroche@gmail.com

CLIENT:
 Mitchell & Danielle Lee
 NJ

PROJECT ADDRESS
 108 & 120 Pond Road
 West Tisbury
 MA 02575

PROJECT NO:
 Q21114
 PROJECT:
 Lee Residence

DRAWN BY:
 RPR
 SHEET:
 Floor Plans

2021.11.02

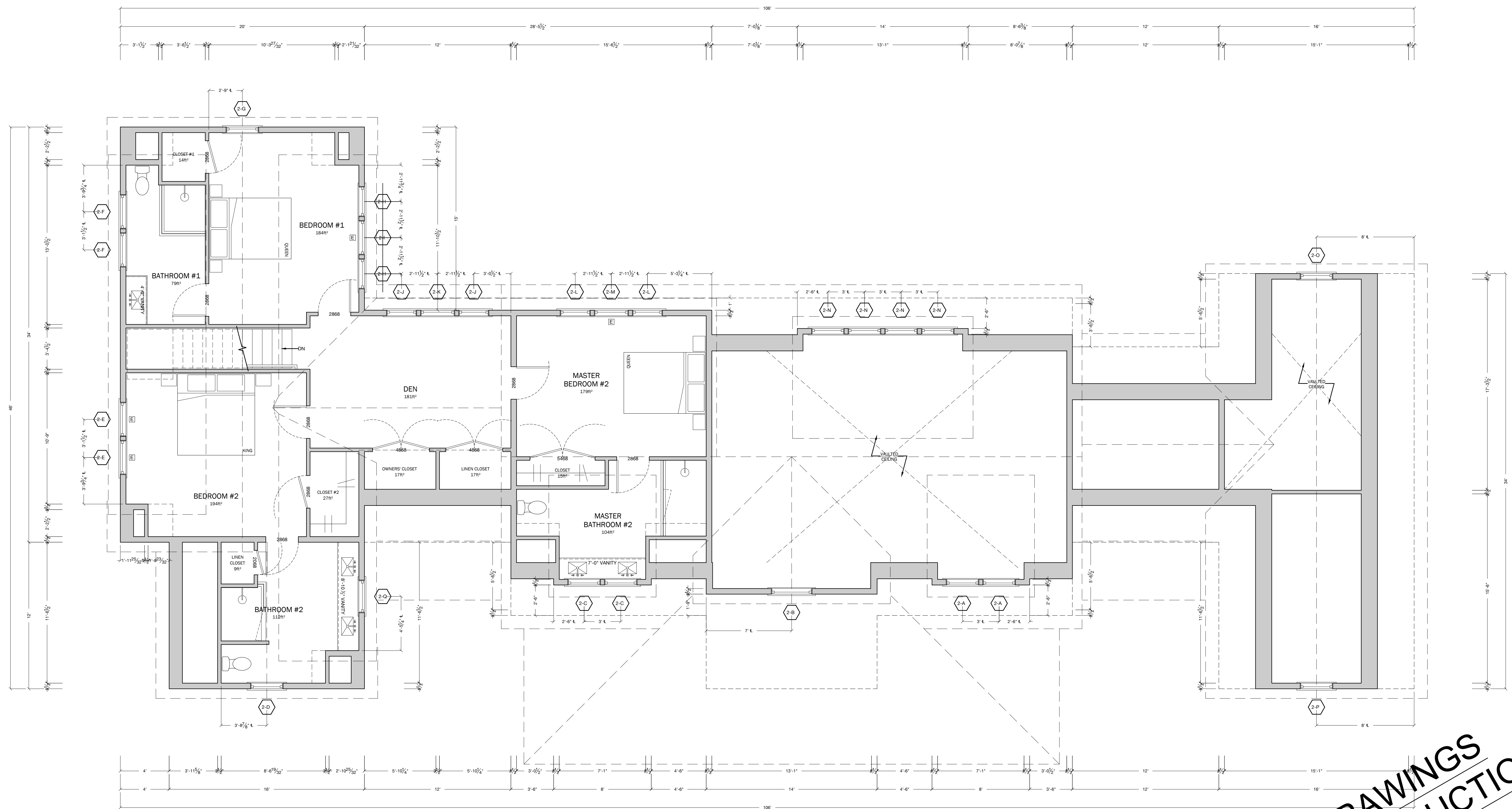

SECOND FLOOR PLAN
 1/4" = 1'-0"
 1,448ft²

**PRICING DRAWINGS
 NOT FOR CONSTRUCTION**

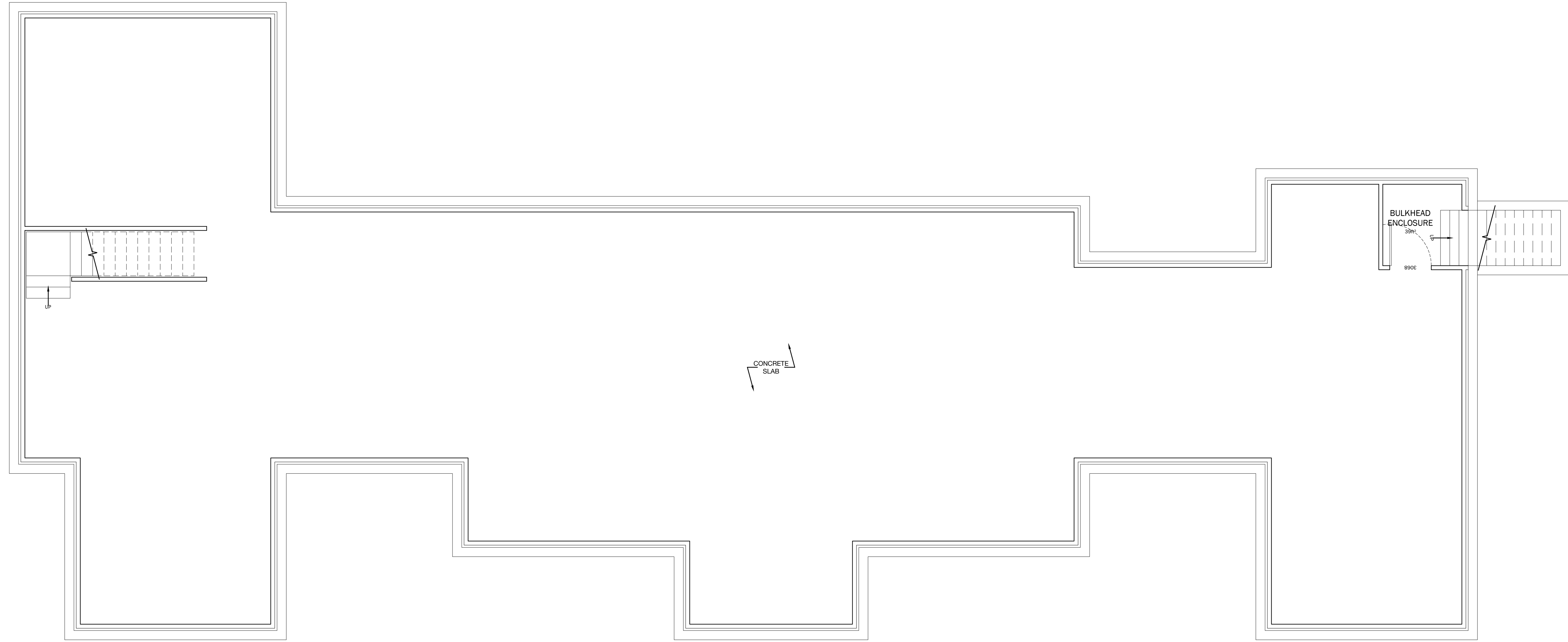

BASEMENT PLAN
 1/4" = 1'-0"

1
 A103

**PRICING DRAWINGS
 NOT FOR CONSTRUCTION**

Quarters Design+Build, LLC
 PO Box 2318
 Vineyard Haven
 MA 02568
 617.671.5798
 robbperroche@gmail.com

CLIENT:
 Mitchell & Danielle Lee
 NJ

PROJECT ADDRESS
 108 & 120 Pond Road
 West Tisbury
 MA 02575

PROJECT NO:
 Q21114
 PROJECT:
 Lee Residence

DRAWN BY:
 RPR
 SHEET:
 Floor Plans

2021.11.02

A

102

SHEET 4 OF 21

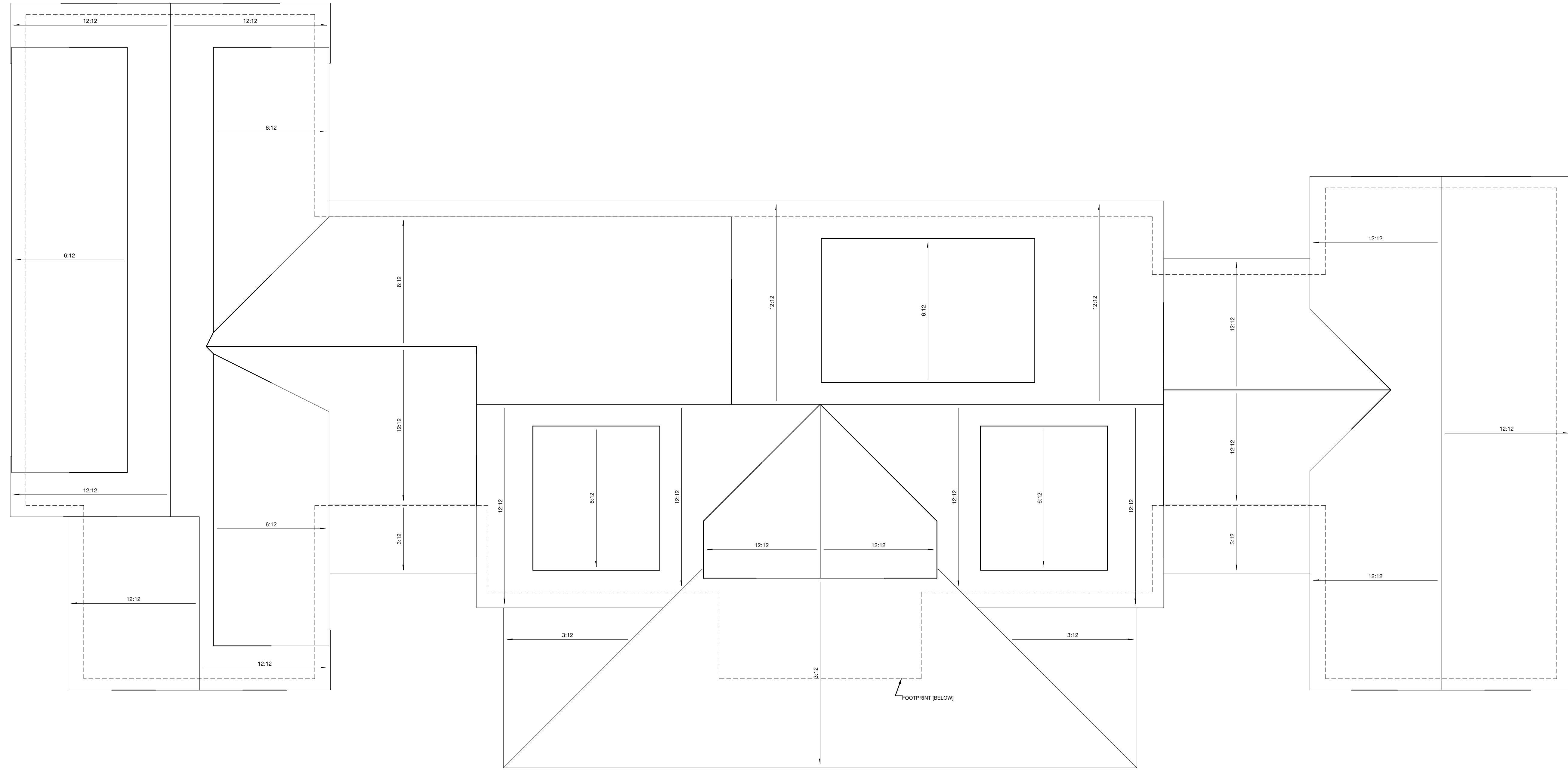

ROOF PLAN
 1/4" = 1'-0"

1
 A104

**PRICING DRAWINGS
 NOT FOR CONSTRUCTION**

Quarters Design+Build, LLC
 PO Box 2318
 Vineyard Haven
 MA 02568
 617.671.5738
 robbperroche@gmail.com

CLIENT:
 Mitchell & Danielle Lee
 NJ

PROJECT ADDRESS
 108 & 120 Pond Road
 West Tisbury
 MA 02575

PROJECT NO:
 Q21114
 PROJECT:
 Lee Residence

DRAWN BY:
 RPR
 SHEET:
 Foundation Plan

2021.11.02

A

104

SHEET 5 OF 21



FRONT ELEVATION
 $\frac{1}{4}'' = 1'-0''$

1
 A201



SIDE ELEVATION
 $\frac{1}{4}'' = 1'-0''$

2
 A201

**PRICING DRAWINGS
 NOT FOR CONSTRUCTION**

Quarters Design+Build, LLC
 P.O. Box 2318
 Vineyard Haven
 MA 02568
 617.671.5738
 robbperroche@gmail.com

CLIENT:
 Mitchell & Danielle Lee
 NJ

PROJECT ADDRESS
 108 & 120 Pond Road
 West Tisbury
 MA 02575

PROJECT NO:
 Q21114
 PROJECT:
 Lee Residence

DRAWN BY:
 RPR
 SHEET:
 Elevations [3]

2021.11.02

A

201

SHEET 6 OF 21

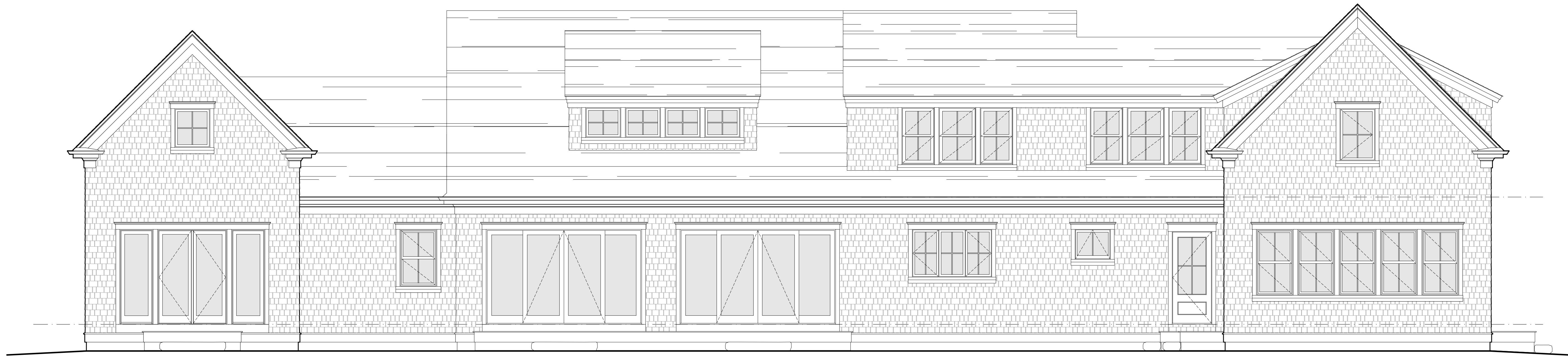

REAR ELEVATION
 $\frac{1}{4}'' = 1'-0''$

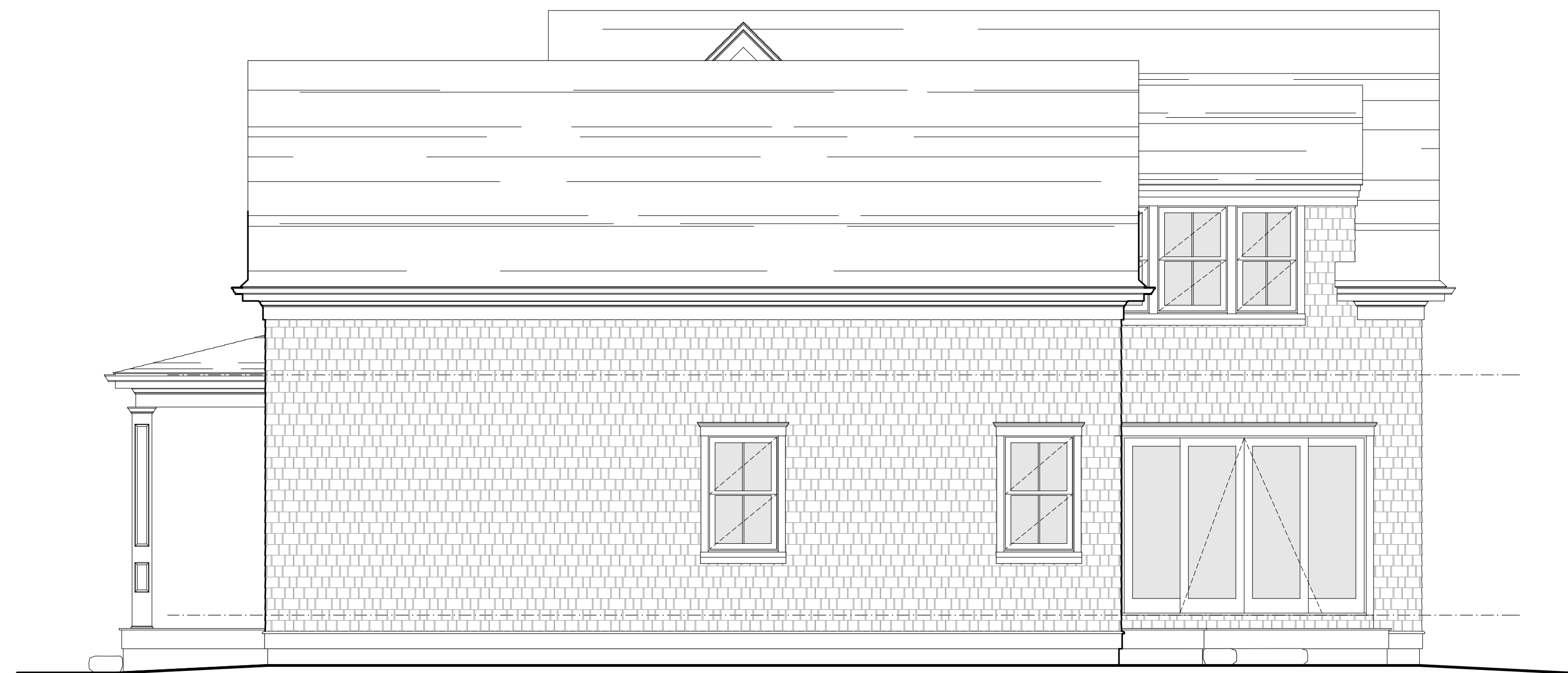
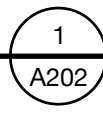

SIDE ELEVATION
 $\frac{1}{4}'' = 1'-0''$

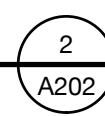

**PRICING DRAWINGS
 NOT FOR CONSTRUCTION**

Quarters Design+Build, LLC
 P.O. Box 2318
 Vineyard Haven
 MA 02568
 617.671.5798
 robbperroche@gmail.com

CLIENT: Mitchell & Danielle Lee
 NJ

PROJECT ADDRESS
 108 & 120 Pond Road
 West Tisbury
 MA 02575

PROJECT NO: Q21114
 PROJECT: Lee Residence

DRAWN BY: RPR
 SHEET: Elevations [2]

2021.11.02

A

202

SHEET 7 OF 21

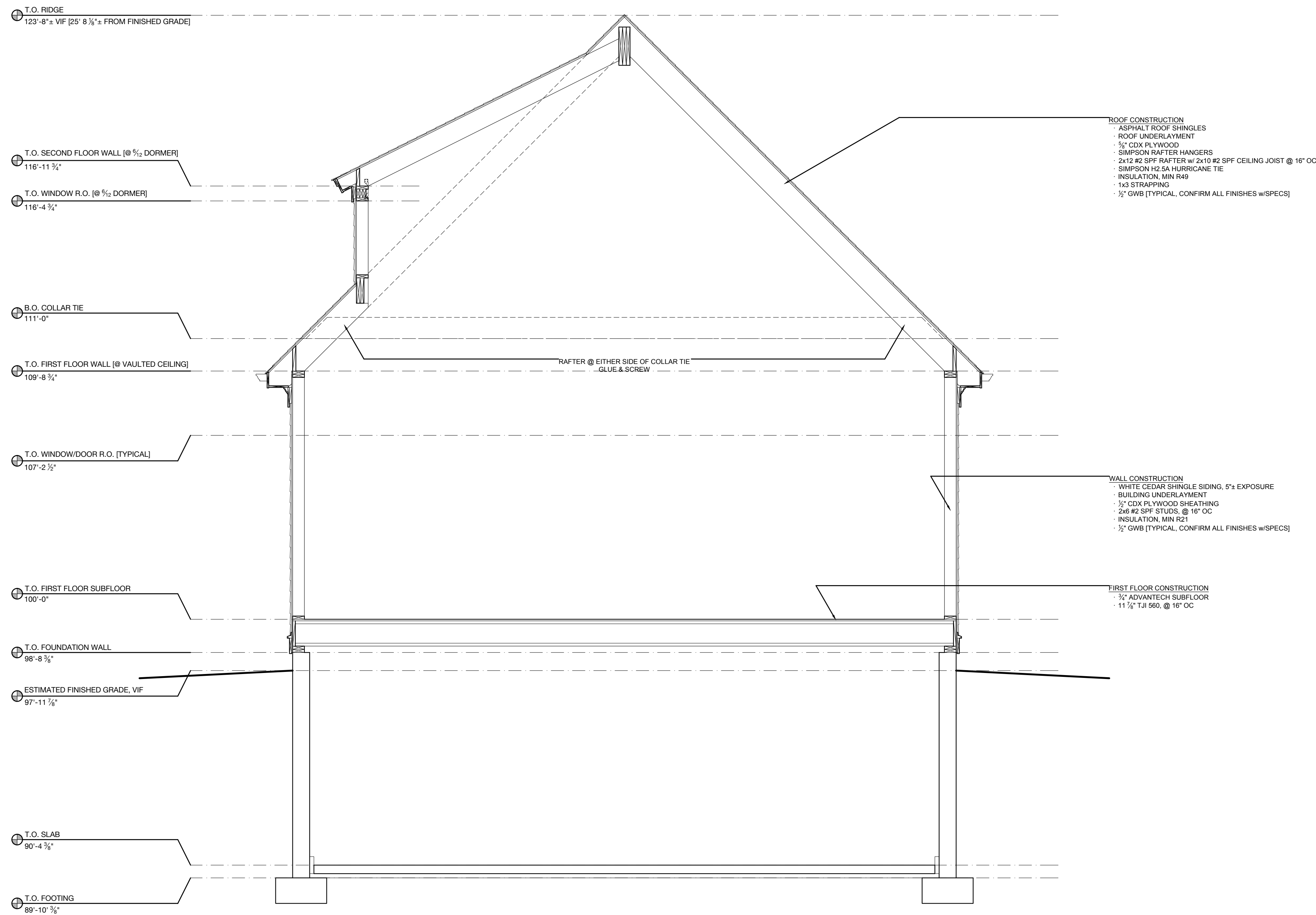

TYPICAL SECTION
3/8" = 1'-0" 1
A301

PRICING DRAWINGS
NOT FOR CONSTRUCTION

Quarters Design+Build, LLC
P.O. Box 2318
Vineyard Haven
MA 02568
617.671.5738
robberroche@gmail.com

CLIENT:
Mitchell & Danielle Lee
NJ

PROJECT ADDRESS:
108 & 120 Pond Road
West Tisbury
MA 02575

PROJECT NO.: Q21114
PROJECT: Lee Residence

DRAWN BY: RPR
SHEET: Typical Section

2021.11.02

A

301

SHEET 8 OF 21

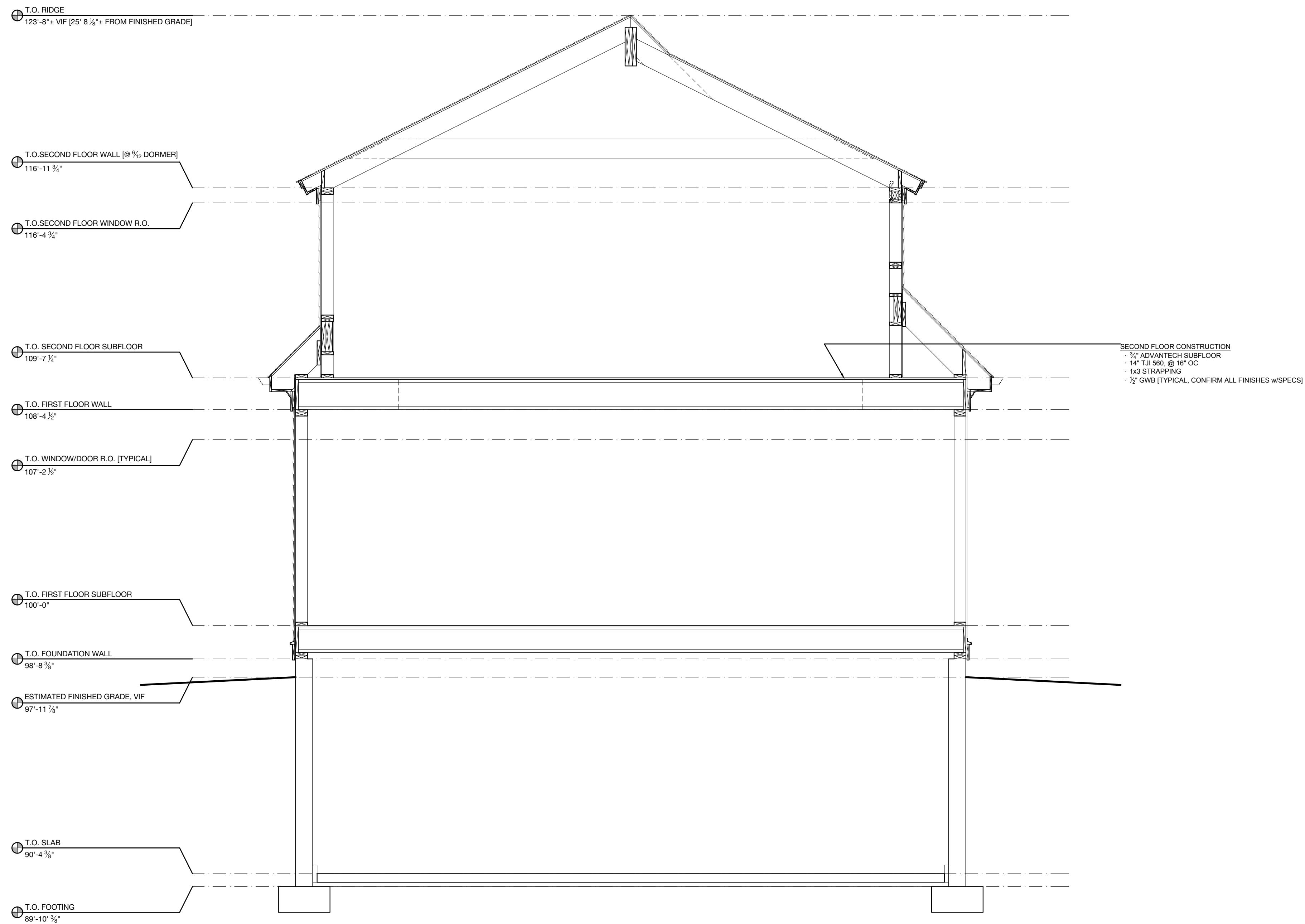

TYPICAL SECTION
 3/8" = 1'-0" 1
A302

PRICING DRAWINGS
NOT FOR CONSTRUCTION

Quarters Design+Build, LLC
 P.O. Box 2318
 Vineyard Haven
 MA 02568
 617.671.5798
 robbierocher@gmail.com

CLIENT:
 Mitchell & Danielle Lee
 NJ

PROJECT ADDRESS
 108 & 120 Pond Road
 West Tisbury
 MA 02575

PROJECT NO:
 Q21114
 PROJECT:
 Lee Residence

DRAWN BY:
 RPR
 SHEET:
 Typical Section

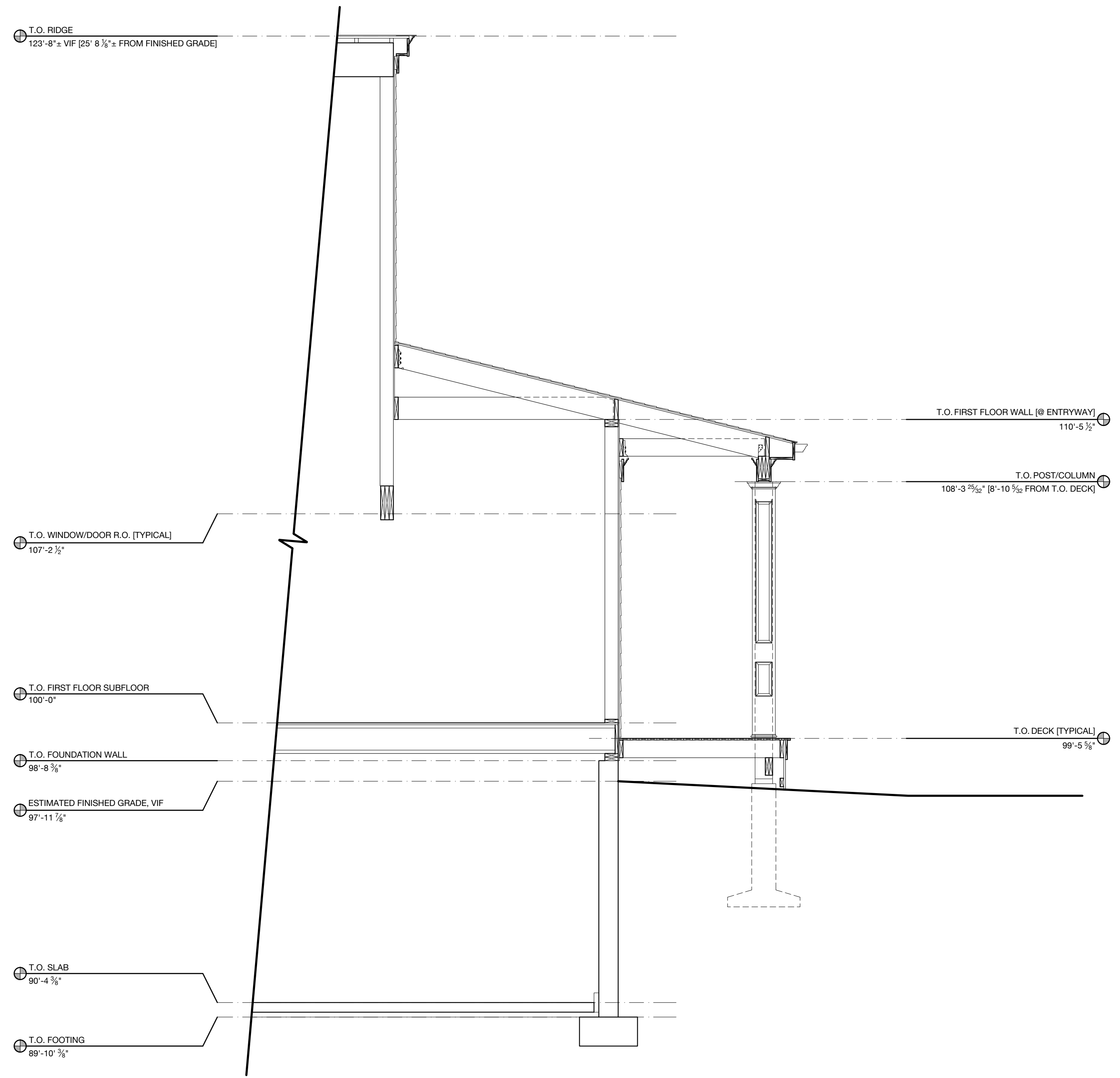

TYPICAL SECTION
 $\frac{3}{8}'' = 1'-0''$
 1
 A303

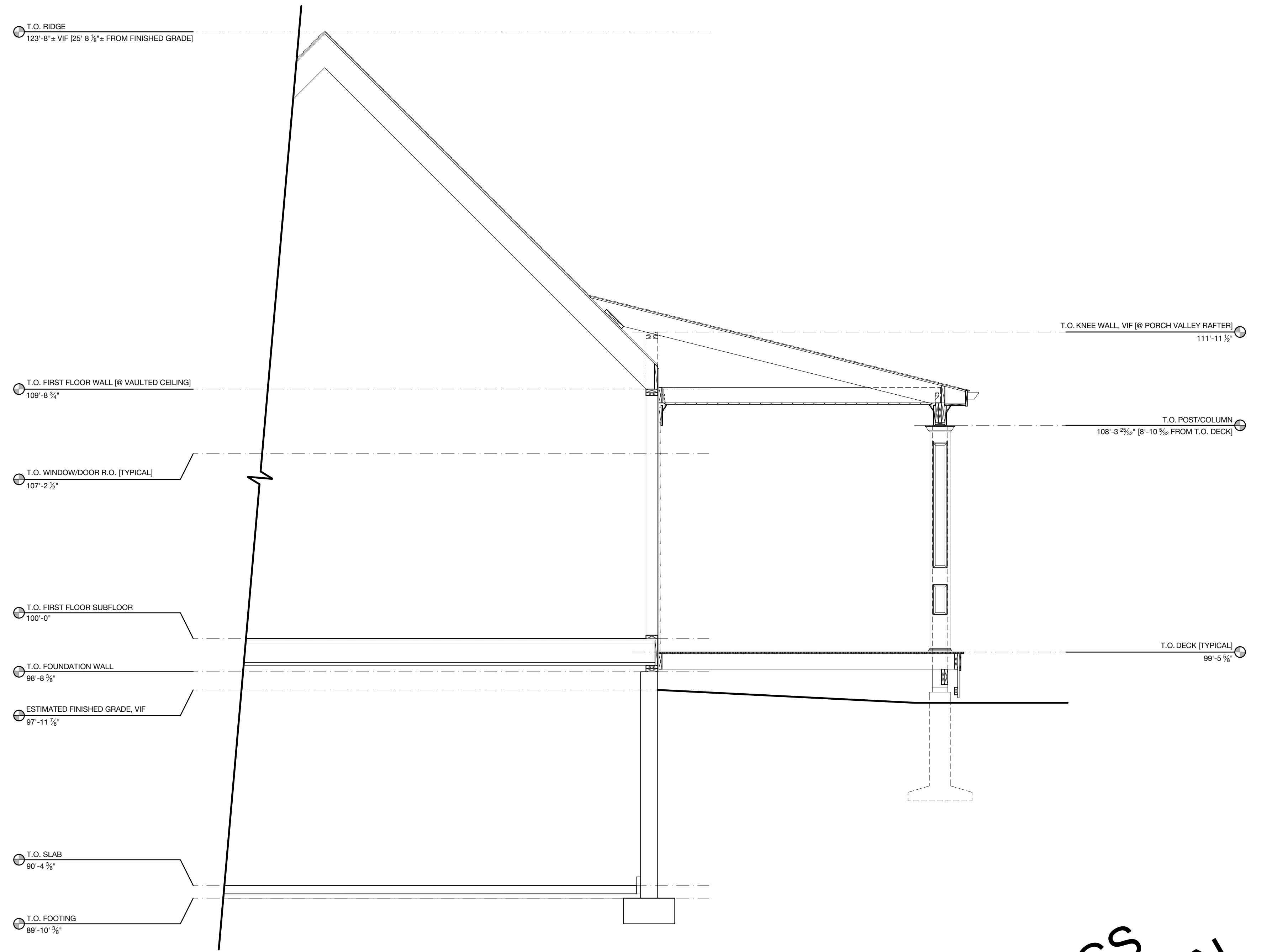

TYPICAL SECTION
 $\frac{3}{8}'' = 1'-0''$
 2
 A303

**PRICING DRAWINGS
 NOT FOR CONSTRUCTION**

Quarters Design+Build, LLC
 P.O. Box 2318
 Vineyard Haven
 MA 02568
 617.671.5738
 robpietroche@gmail.com

CLIENT:
 Mitchell & Danielle Lee
 NJ

PROJECT ADDRESS:
 108 & 120 Pond Road
 West Tisbury
 MA 02575

PROJECT NO.:
 Q21114
 PROJECT:
 Lee Residence

DRAWN BY:
 RPR
 SHEET:
 Typical Section

2021.11.02

A

303

SHEET 10 OF 21

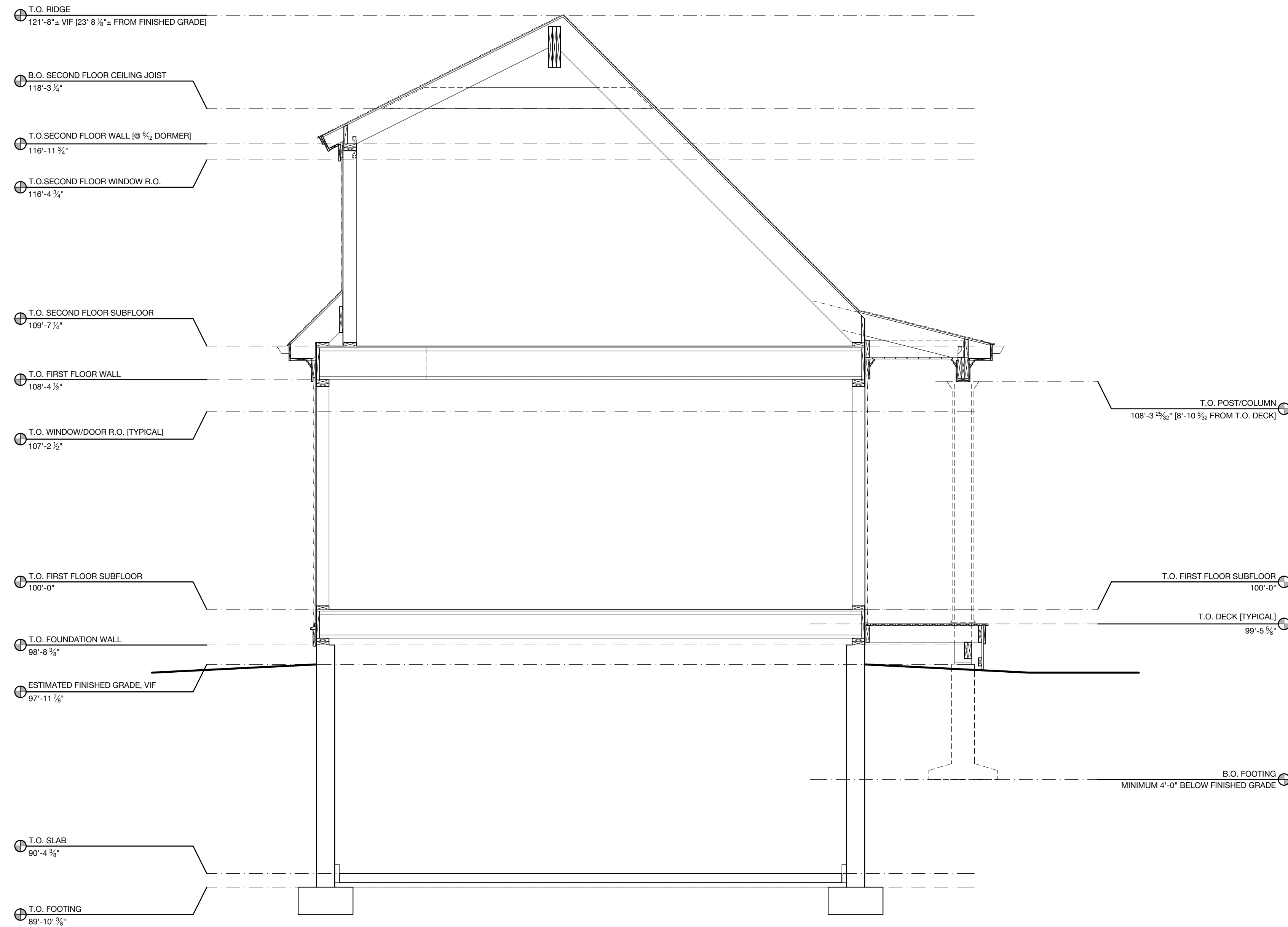

TYPICAL SECTION
 $\frac{3}{8}'' = 1'-0''$

1
 A304

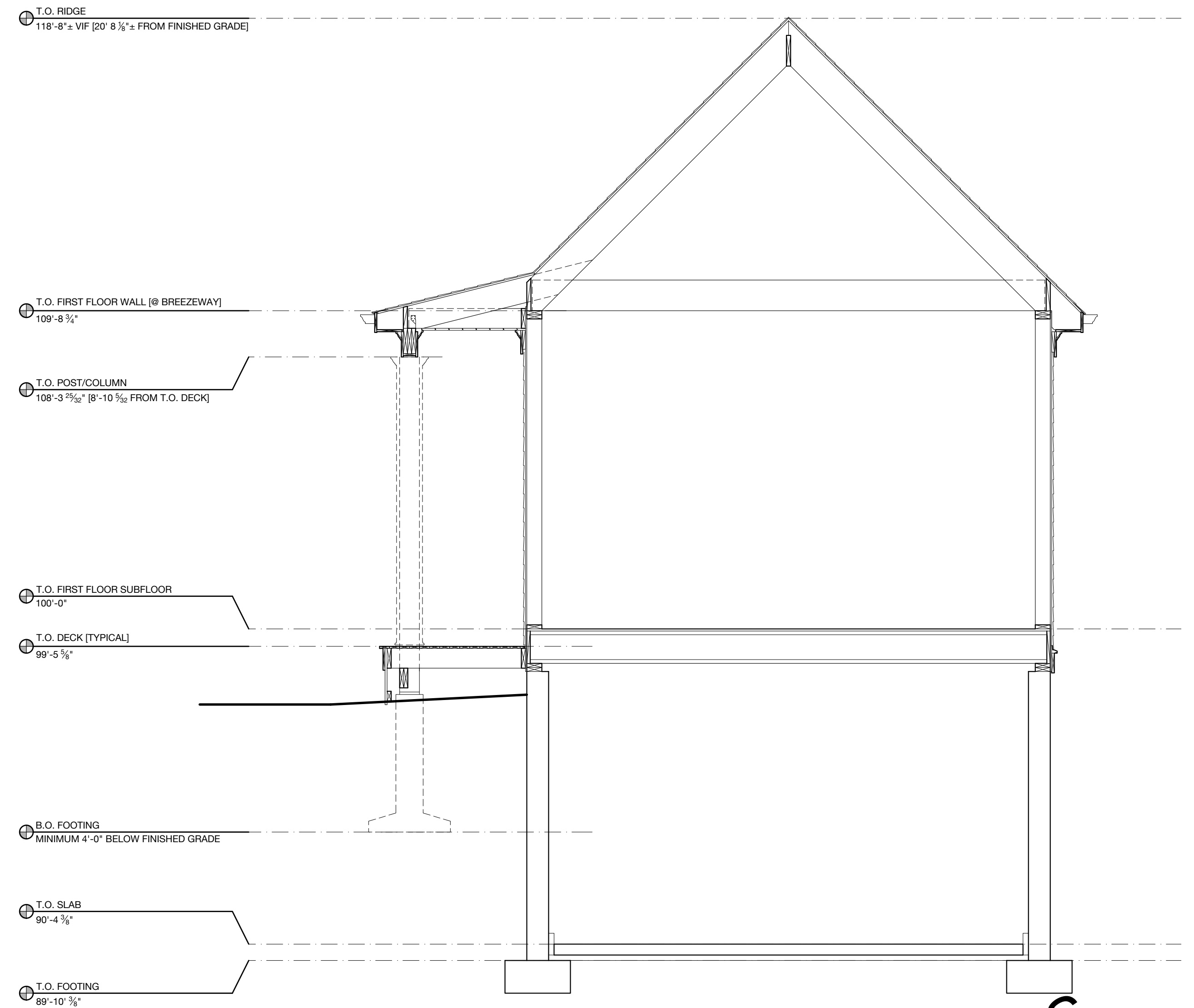

TYPICAL SECTION
 $\frac{3}{8}'' = 1'-0''$

2
 A304

**PRICING DRAWINGS
 NOT FOR CONSTRUCTION**

Quarters Design+Build, LLC
 P.O. Box 2318
 Vineyard Haven
 MA 02568
 617.671.5798
 rob@quartersdesign.com

CLIENT:
 Mitchell & Danielle Lee
 NJ

PROJECT ADDRESS:
 108 & 120 Pond Road
 West Tisbury
 MA 02575

PROJECT NO.:
 Q21114
 PROJECT:
 Lee Residence

DRAWN BY:
 RPR
 SHEET:
 Typical Section

2021.11.02

A

304

SHEET 11 OF 21

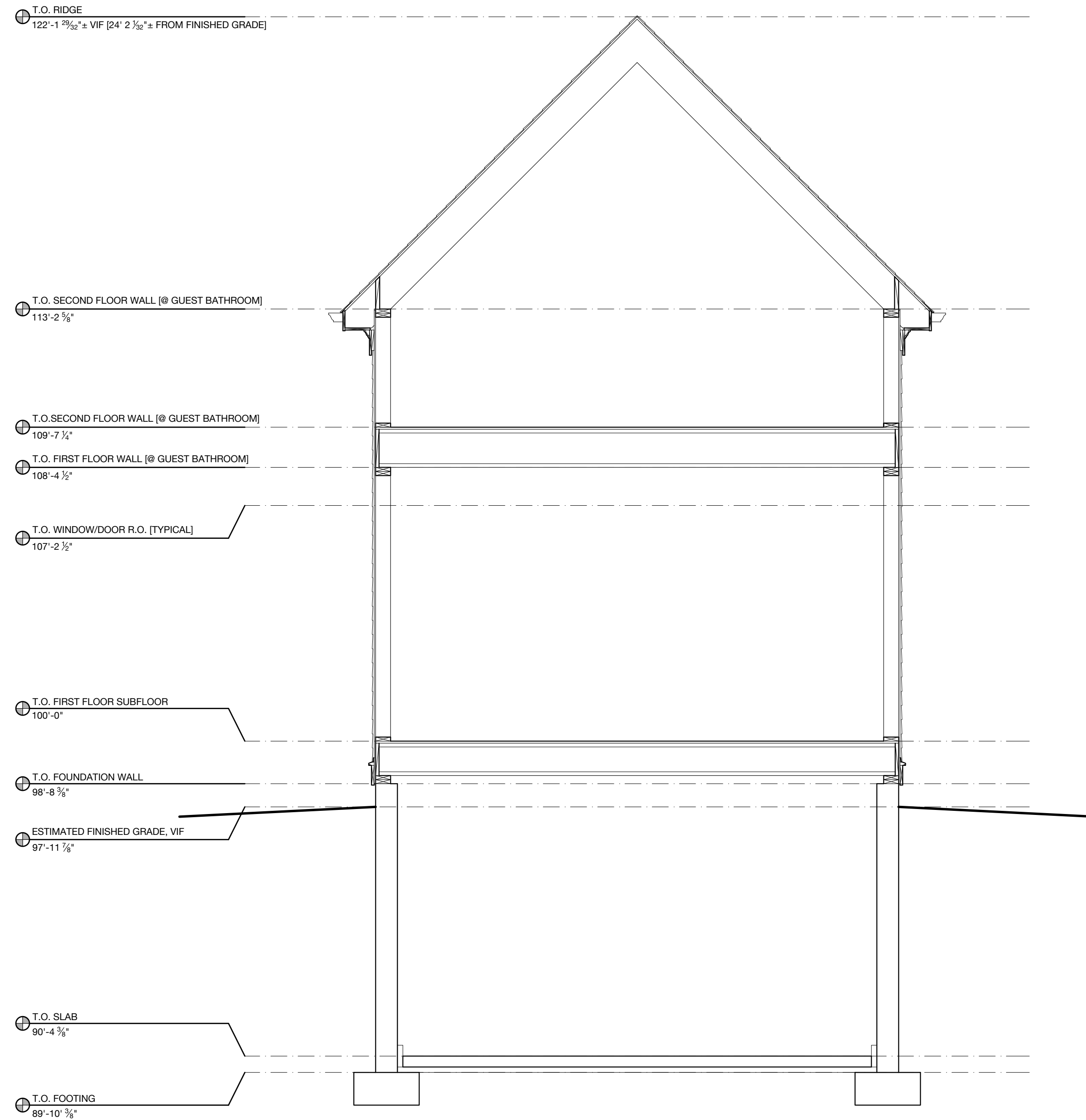

TYPICAL SECTION
 $\frac{3}{8}'' = 1'-0''$

1
 A305

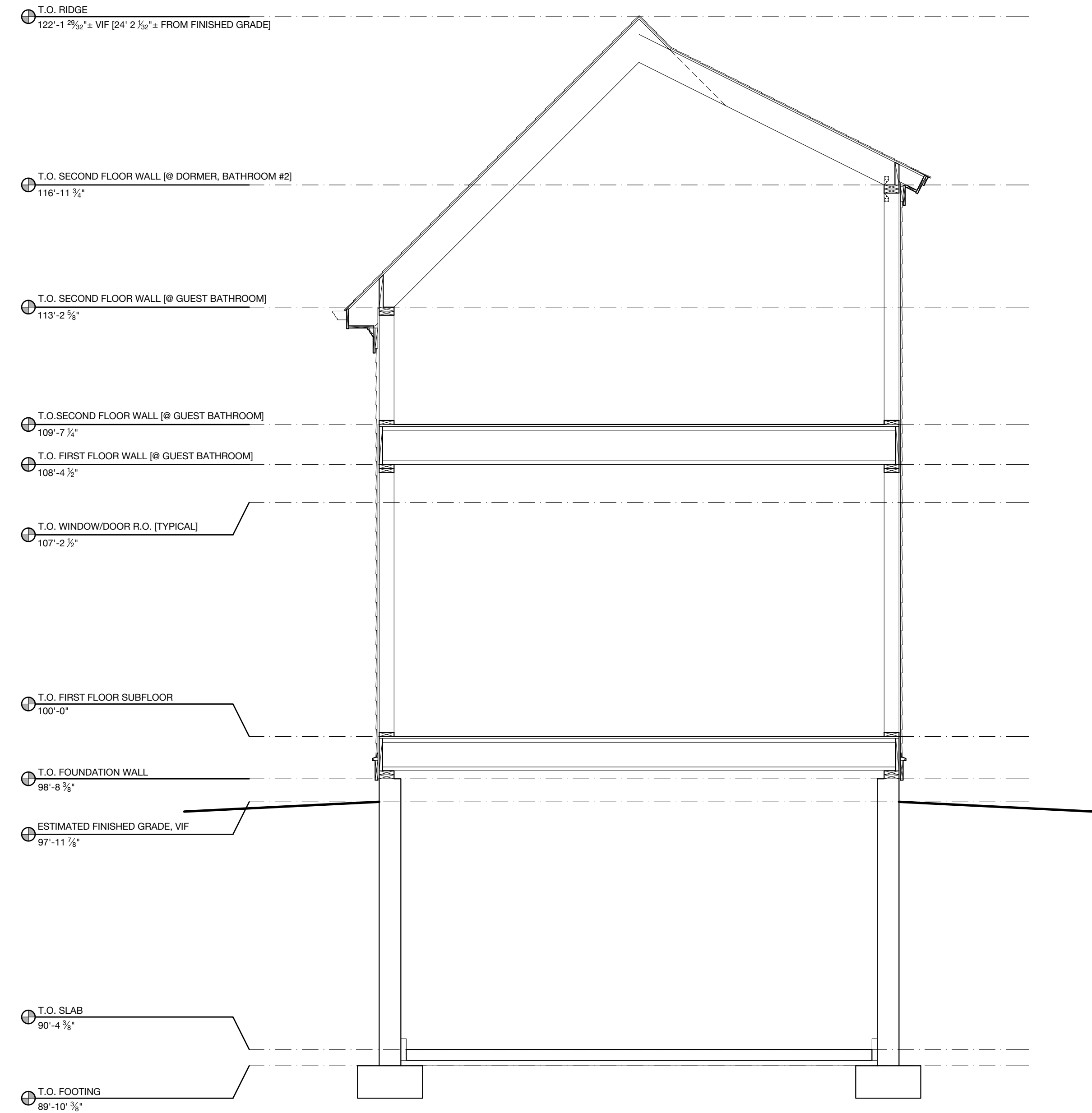

TYPICAL SECTION
 $\frac{3}{8}'' = 1'-0''$

2
 A305

**PRICING DRAWINGS
 NOT FOR CONSTRUCTION**

Quarters Design+Build, LLC
 P.O. Box 2318
 Vineyard Haven
 MA 02568
 617.671.5738
 robbierocche@gmail.com

CLIENT:
 Mitchell & Danielle Lee
 NJ

PROJECT ADDRESS:
 108 & 120 Pond Road
 West Tisbury
 MA 02575

PROJECT NO.:
 Q21114
 PROJECT:
 Lee Residence

DRAWN BY:
 RPR
 SHEET:
 Typical Section

2021.11.02

A

305

SHEET 12 OF 21

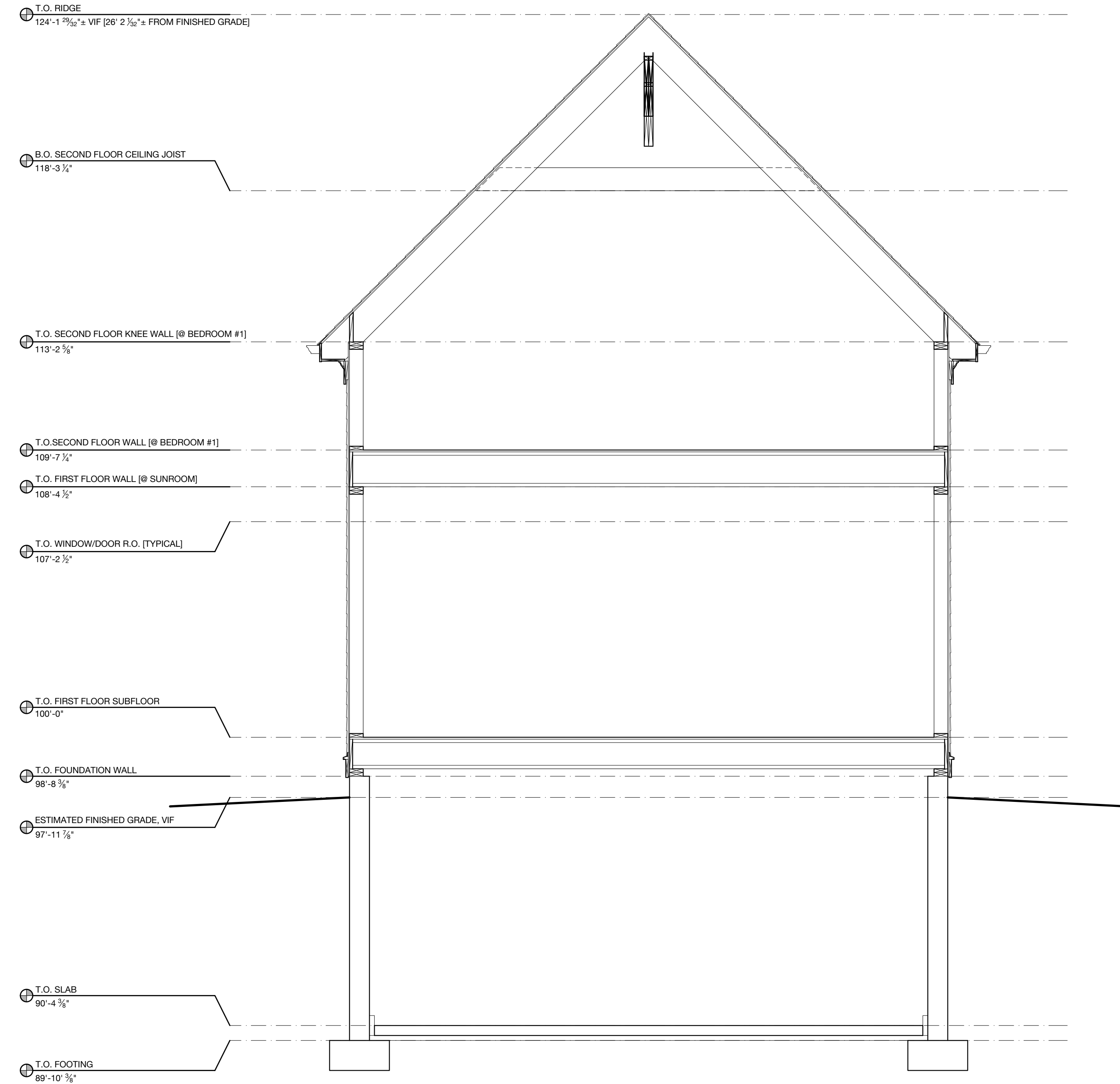

TYPICAL SECTION
 $\frac{3}{8}'' = 1'-0''$

1
 A306

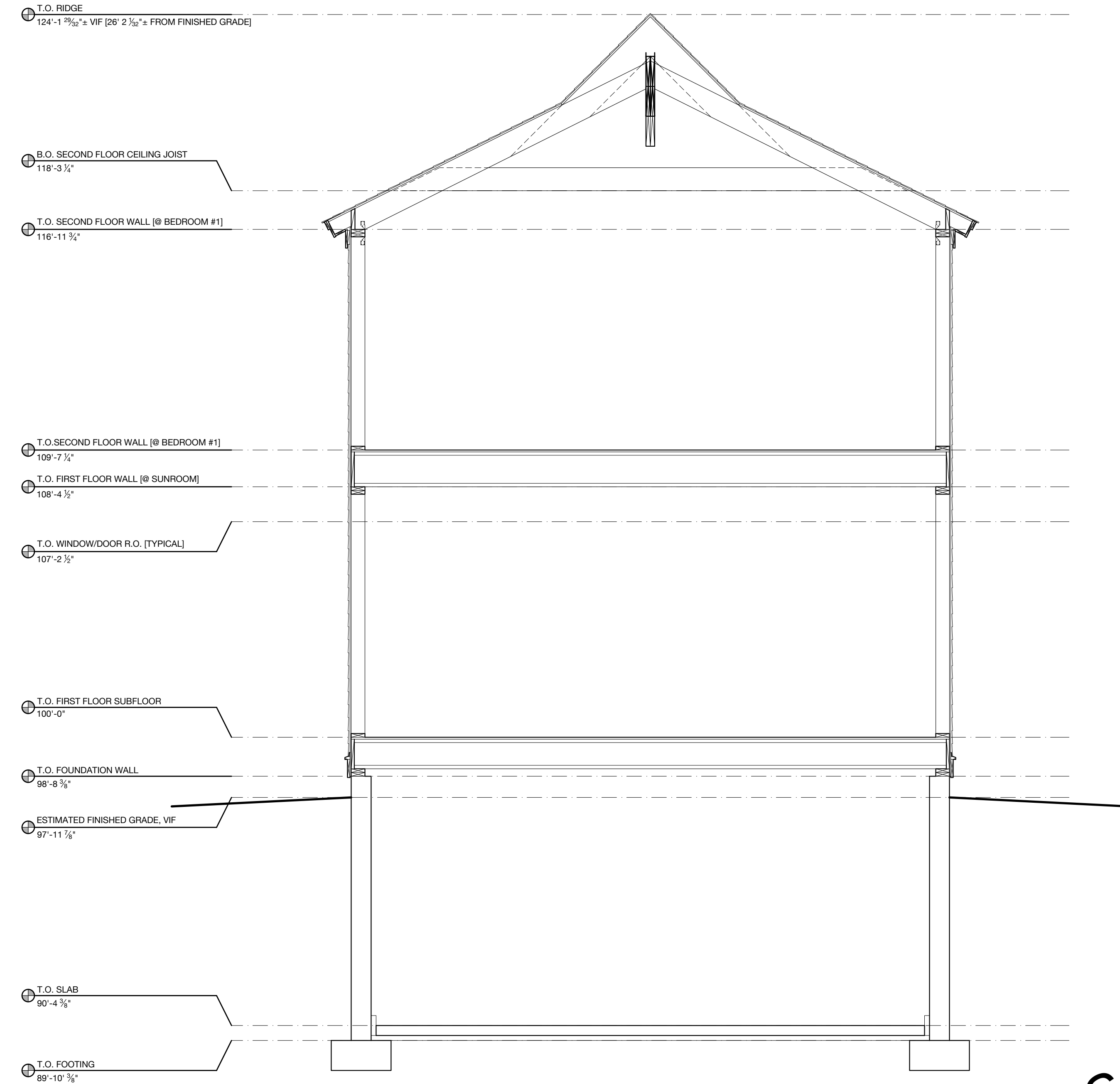

TYPICAL SECTION
 $\frac{3}{8}'' = 1'-0''$

2
 A306

**PRICING DRAWINGS
 NOT FOR CONSTRUCTION**

Quarters Design+Build, LLC
 P.O. Box 2318
 Vineyard Haven
 MA 02568
 617.671.5738
 rob@quartersdesign.com

CLIENT:
 Mitchell & Danielle Lee
 NJ

PROJECT ADDRESS:
 108 & 120 Pond Road
 West Tisbury
 MA 02575

PROJECT NO.:
 Q21114
 PROJECT:
 Lee Residence

DRAWN BY:
 RPR
 SHEET:
 Typical Section

2021.11.02

A

306

SHEET 13 OF 21

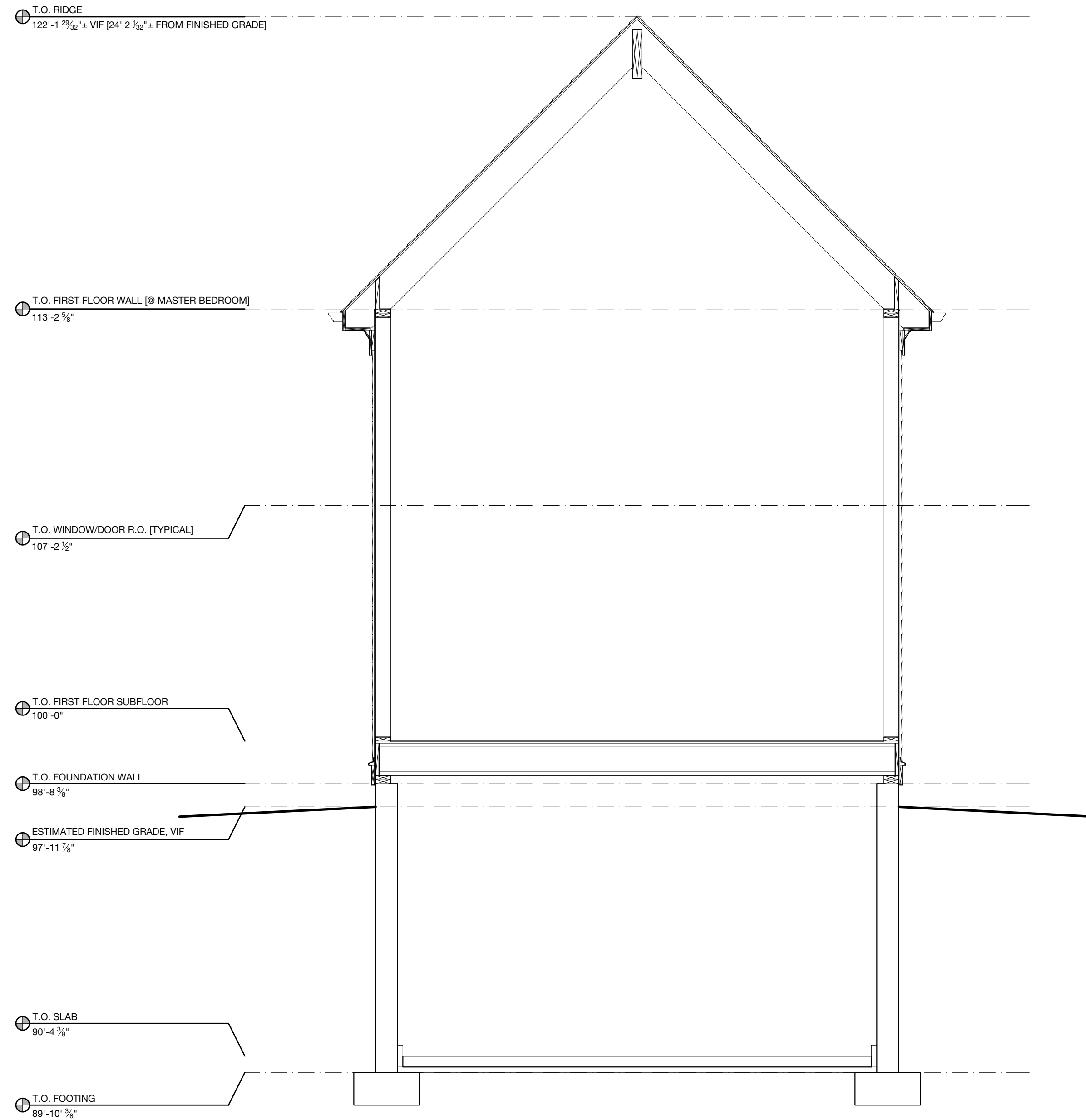

TYPICAL SECTION 1
 $\frac{3}{8}'' = 1'-0''$ A307

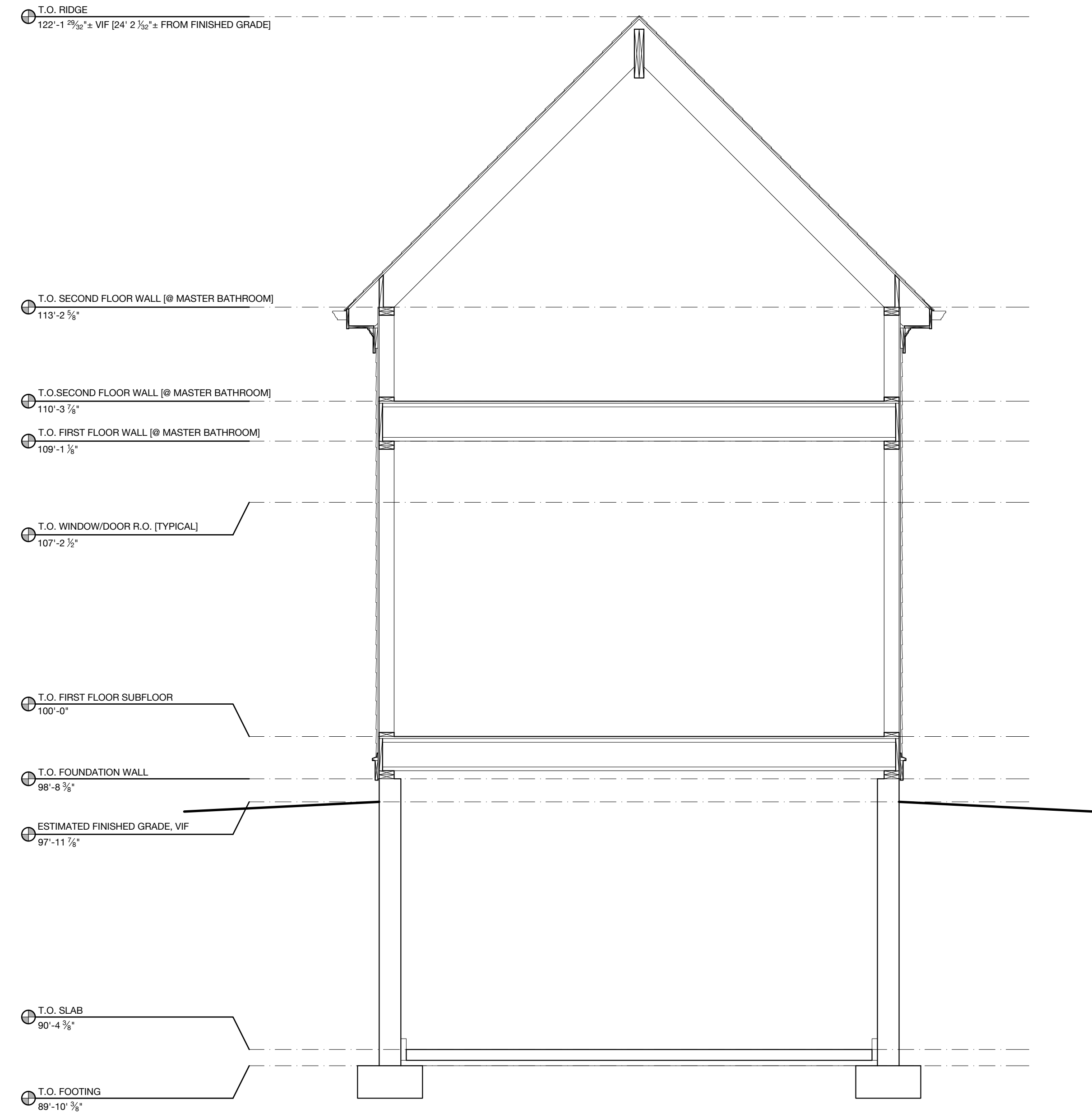

TYPICAL SECTION 2
 $\frac{3}{8}'' = 1'-0''$ A307

**PRICING DRAWINGS
 NOT FOR CONSTRUCTION**

Quarters Design+Build, LLC
 P.O. Box 2318
 Vineyard Haven
 MA 02568
 617.671.5798
 robbperroche@gmail.com

CLIENT:
 Mitchell & Danielle Lee
 NJ

PROJECT ADDRESS
 108 & 120 Pond Road
 West Tisbury
 MA 02575

PROJECT NO:
 Q21114
 PROJECT:
 Lee Residence

DRAWN BY:
 RPR
 SHEET:
 Typical Section

2021.11.02

A

307

SHEET 14 OF 21

TAG	BRAND	MODEL	PRODUCT	UNIT WIDTH	UNIT HEIGHT	QUANTITY	LITES	LOCATION	NOTES	COLOR
WINDOW										
1-A	Marvin	Elevate	ITDH3256	2'-7 1/2"	4'-7 3/4"	6	3/2	Living/Breakfast	-	White
1-B	Marvin	Elevate	ITDH3056	2'-5 1/2"	4'-7 3/4"	2	3/2	Mudroom	-	White
1-C	Marvin	Elevate	ICA3355	2'-8"	4'-7 3/4"	1	-	Guest Bedroom	Egress	White
1-D	Marvin	Elevate	ITDH3252	2'-7 1/2"	4'-3 3/4"	2	3/2	Guest Bedroom	-	White
1-E	Marvin	Elevate	IAWN4127 2W	6'-8"	2'-3 1/8"	1	2w1h	Guest Bedroom	-	White
1-F	Marvin	Elevate	IAWN2527	2'-0"	2'-3 1/8"	1	2w1h	Guest Bathroom	Tempered	White
1-G	Marvin	Elevate	IAWN2527	2'-0"	2'-3 1/8"	1	2w1h	Stairway	Tempered	White
1-H	Marvin	Elevate	ITDH3460	2'-9 1/2"	4'-11 3/4"	4	3/2	Sunroom	-	White
1-I	Marvin	Elevate	ITDH3460	2'-9 1/2"	4'-11 3/4"	5	3/2	Sunroom	-	White
1-J	Marvin	Elevate	IAWN3327	2'-8"	2'-3 1/8"	1	2w1h	Powder Room	Tempered	White
1-K	Marvin	Elevate	ICA2543 3W	6'-0"	3'-7 1/4"	1	2w2h w/SCR	Kitchen	Tempered	White
1-L	Marvin	Elevate	ITDH3452	2'-9 1/2"	4'-3 3/4"	1	3/2	Office	-	White
1-M	Marvin	Elevate	11FD2670 O	2'-6 5/16"	7'-2"	2	TBD	Master Bedroom	-	White
1-N	Marvin	Elevate	ITDH3456	2'-9 1/2"	4'-7 3/4"	2	3/2	Master Bedroom	Egress	White
1-O	Marvin	Elevate	ITDH3252	2'-7 1/2"	4'-3 3/4"	2	3/2	Master Bathroom	Tempered	White
1-P	Marvin	Elevate	IAWN3327	2'-8"	2'-3 1/8"	1	2w1h	Master W.C.	Tempered	White
1-Q	Marvin	Elevate	ITDH3056	2'-5 1/2"	4'-7 3/4"	2	3/2	Hallway	-	White

FIRST FLOOR WINDOW SCHEDULE 1
A401

TAG	BRAND	MODEL	PRODUCT	UNIT WIDTH	UNIT HEIGHT	QUANTITY	LITES	LOCATION	NOTES	COLOR
DOOR										
1-1	TBD between Owner & Contractor			3'-6"	8'-0"	1	TBD	Front Entryway	-	TBD
1-2	TBD between Owner & Contractor			3'-0"	7'-2"	1	TBD	Mudroom	-	TBD
1-3	TBD between Owner & Contractor			3'-0"	7'-0"	1	TBD	Mudroom	-	TBD
1-4	Marvin	Elevate	ISFD10070	9'-9"	7'-2"	1	TBD	Sunroom	-	White
1-5	TBD between Owner & Contractor			3'-0"	7'-0"	1	TBD	Mudroom	-	TBD
1-6	Marvin	Elevate	ISFD12070	11'-9"	7'-2"	2	TBD	Dining/Living Area	-	White
1-7	Marvin	Elevate	IIFD5470 XX	5'-3"	7'-2"	1	TBD	Master Bedroom	-	White
1-8	TBD between Owner & Contractor			3'-0"	7'-2"	1	TBD	Breezeway	-	TBD

FIRST FLOOR DOOR SCHEDULE 2
A401

TAG	BRAND	MODEL	PRODUCT	UNIT WIDTH	UNIT HEIGHT	QUANTITY	LITES	LOCATION	NOTES	COLOR
WINDOW										
2-A	Marvin	Elevate	IAWN3327	2'-8"	2'-3 1/8"	2	2w2h	Living Area	Tempered	White
2-B	Marvin	Elevate	IAWN4147	3'-4"	3'-11 1/8"	1	2w2h	Living Area	Tempered	White
2-C	Marvin	Elevate	IAWN3327	2'-8"	2'-3 1/8"	2	2w2h	Master Bathroom #2	Tempered	White
2-D	Marvin	Elevate	IAWN3335	2'-8"	2'-11 1/8"	1	2w2h	Bathroom #2	Tempered	White
2-E	Marvin	Elevate	ITDH3452	2'-9 1/2"	4'-3 3/4"	2	3/2	Bedroom #2	Egress	White
2-F	Marvin	Elevate	ITDH3452	2'-9 1/2"	4'-3 3/4"	2	3/2	Bathroom #1	Tempered	White
2-G	Marvin	Elevate	IAWN3347	2'-8"	3'-11 1/8"	1	2w2h	Bedroom #1	-	White
2-H	Marvin	Elevate	ITDH3052	2'-5 1/2"	4'-3 3/4"	2	3/2	Bedroom #1	-	White
2-I	Marvin	Elevate	ITDH3452	2'-9 1/2"	4'-3 3/4"	1	3/2	Bedroom #1	Egress	White
2-J	Marvin	Elevate	ITDH3052	2'-5 1/2"	4'-3 3/4"	2	3/2	Den	-	White
2-K	Marvin	Elevate	ITDH3452	2'-9 1/2"	4'-3 3/4"	1	3/2	Den	-	White
2-L	Marvin	Elevate	ITDH3052	2'-5 1/2"	4'-3 3/4"	2	3/2	Master Bedroom #2	-	White
2-M	Marvin	Elevate	ITDH3452	2'-9 1/2"	4'-3 3/4"	1	3/2	Master Bedroom #2	Egress	White
2-N	Marvin	Elevate	IAWN3327	2'-8"	2'-3 1/8"	4	2w2h	Living Area	Tempered	White
2-O	Marvin	Elevate	IAWN3335	2'-8"	2'-11 1/8"	1	2w2h	Master Bedroom [vaulted]	Tempered	White
2-P	Marvin	Elevate	IAWN3335	2'-8"	2'-11 1/8"	1	2w2h	Attic	-	White
2-Q	Marvin	Elevate	IAWN3339	2'-8"	3'-3 1/8"	1	2w2h	Bathroom #2	Tempered	White

SECOND FLOOR WINDOW SCHEDULE 3
A401

PRICING DRAWINGS
NOT FOR CONSTRUCTION

Quarters Design+Build, LLC
P.O. Box 2318
Vineyard Haven
MA 02568
617.671.5798
robberroche@gmail.com

CLIENT: Mitchell & Danielle Lee
NJ

PROJECT ADDRESS: 108 & 120 Pond Road
West Tisbury
MA 02575

PROJECT NO: Q21114
PROJECT: Lee Residence

DRAWN BY: RPR
SHEET: Schedules

2021.11.02

A

401

SHEET 15 OF 21

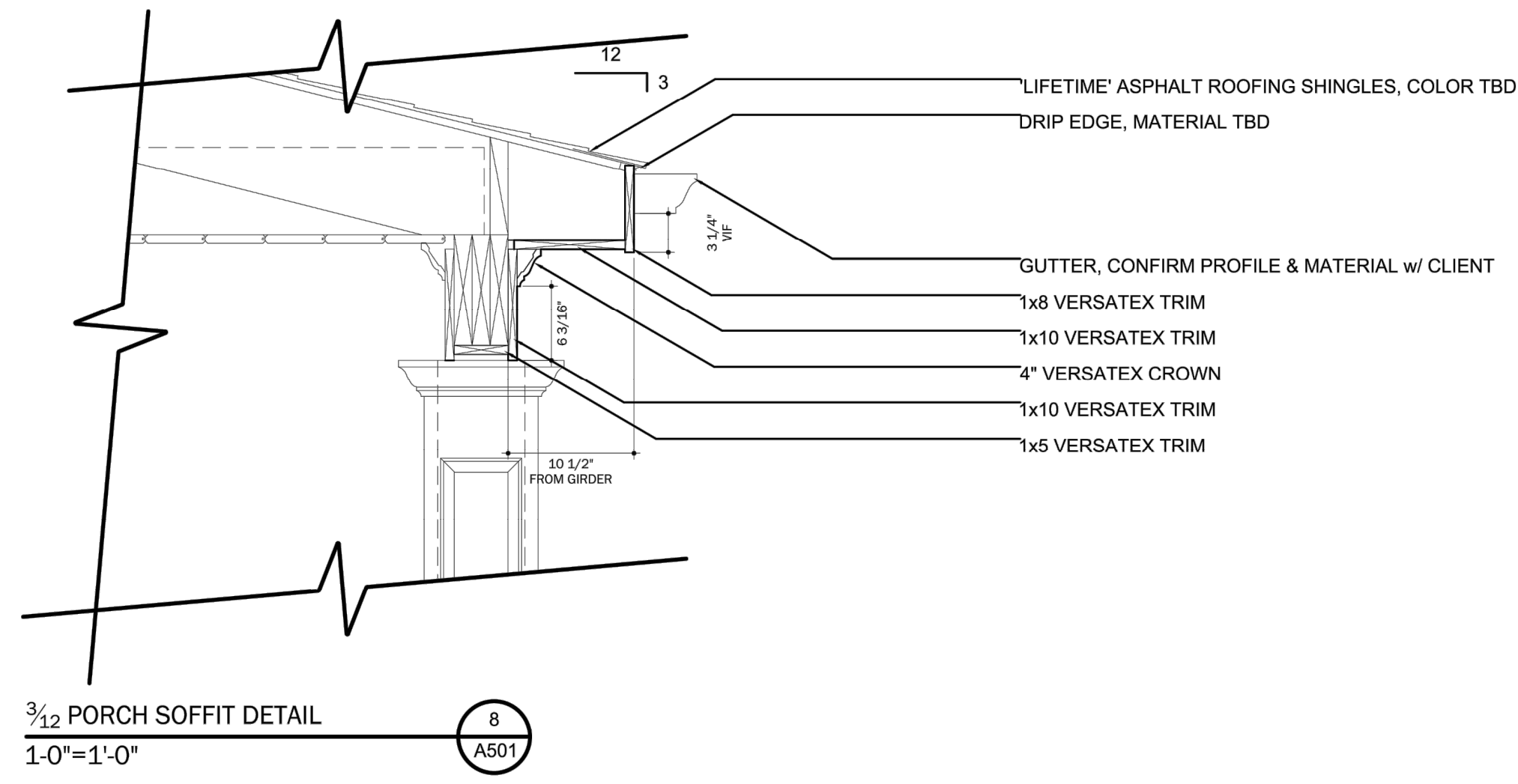
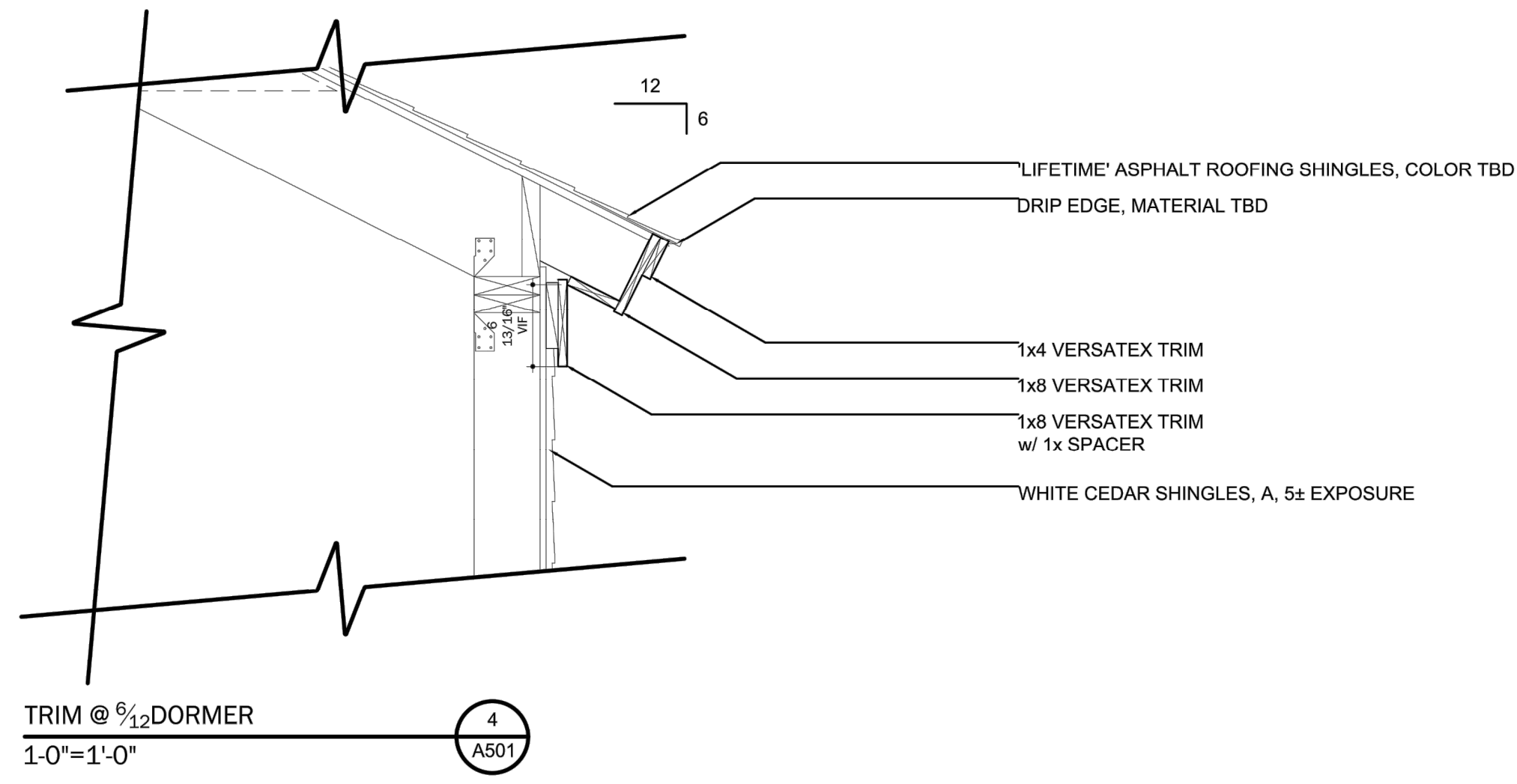
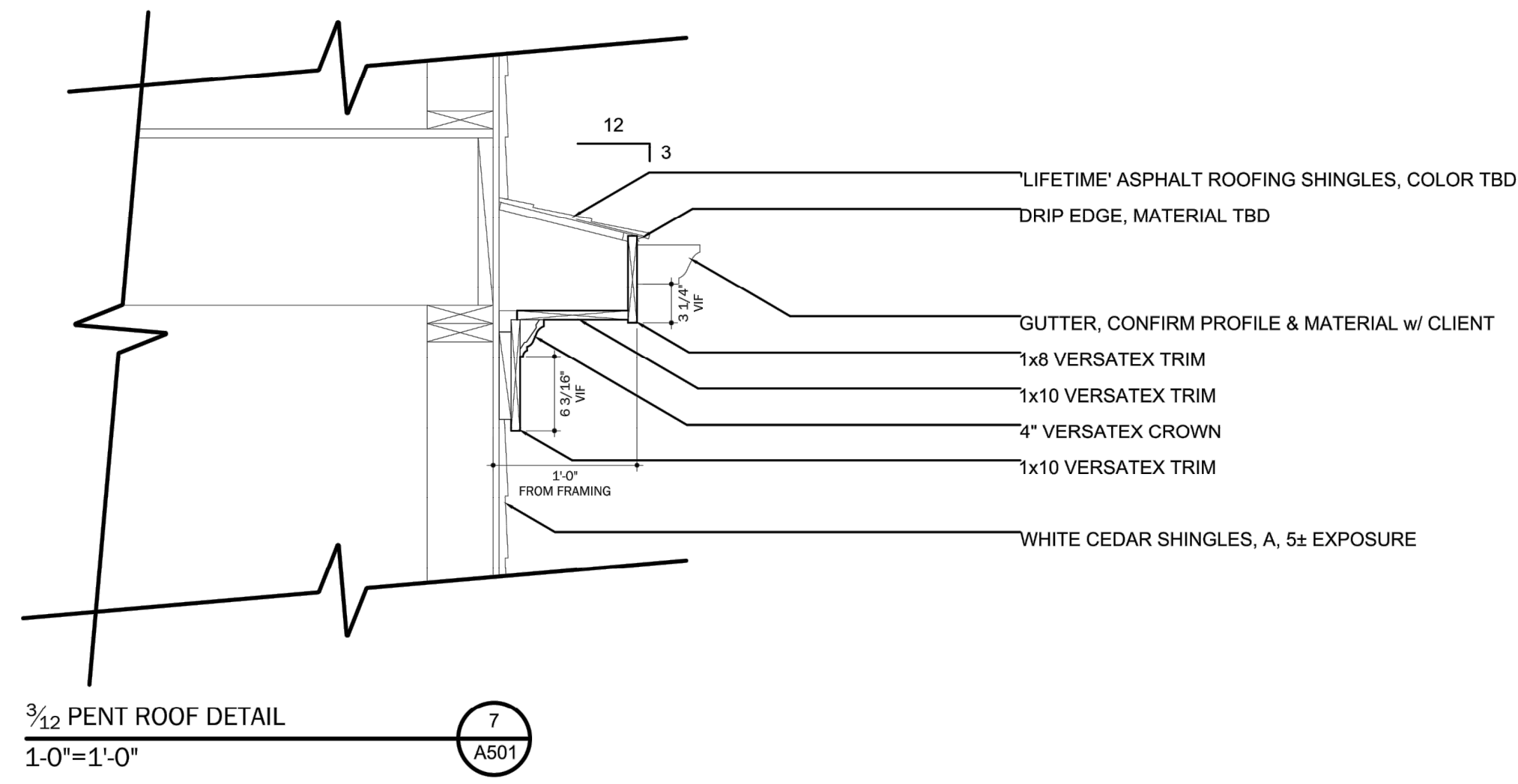
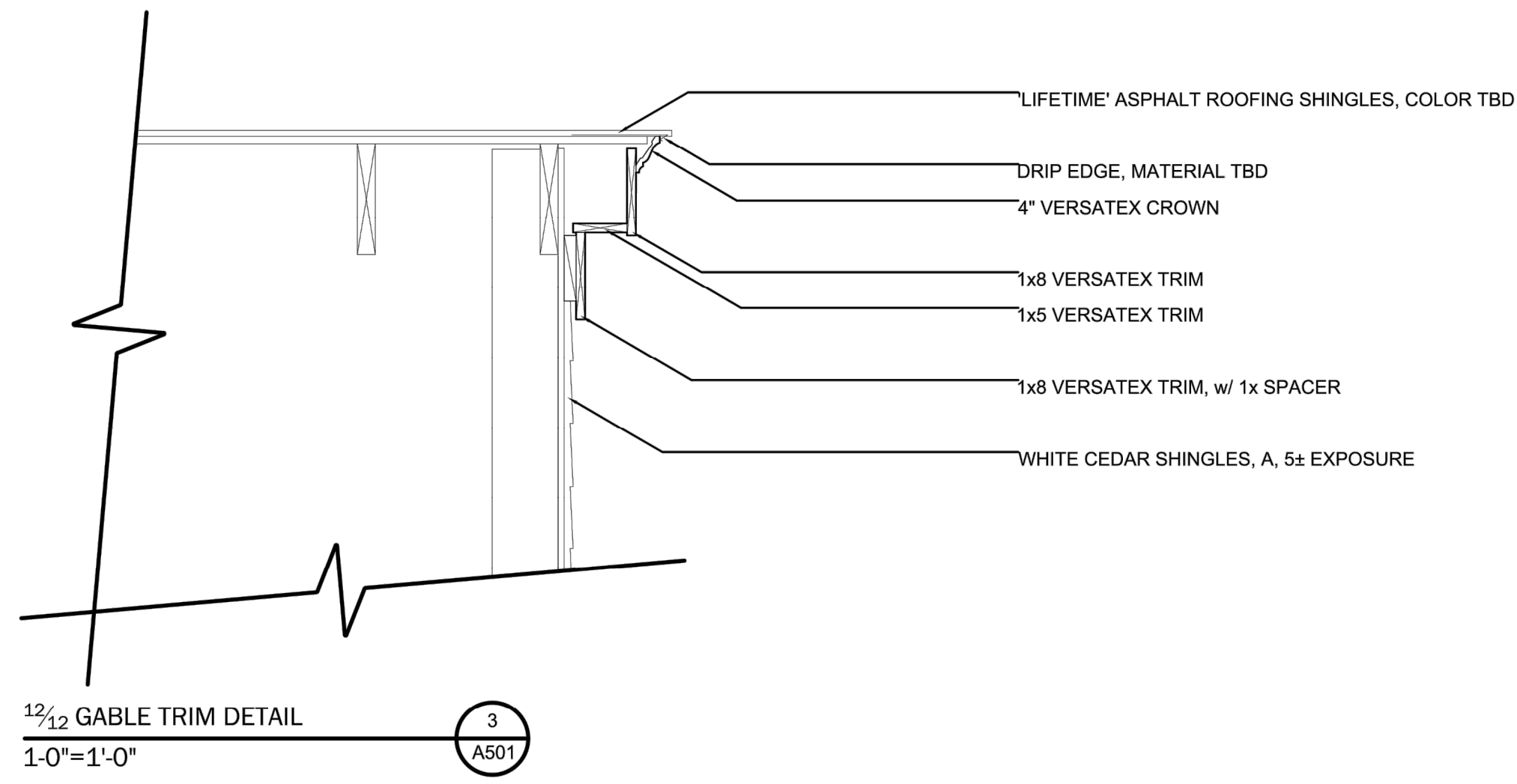
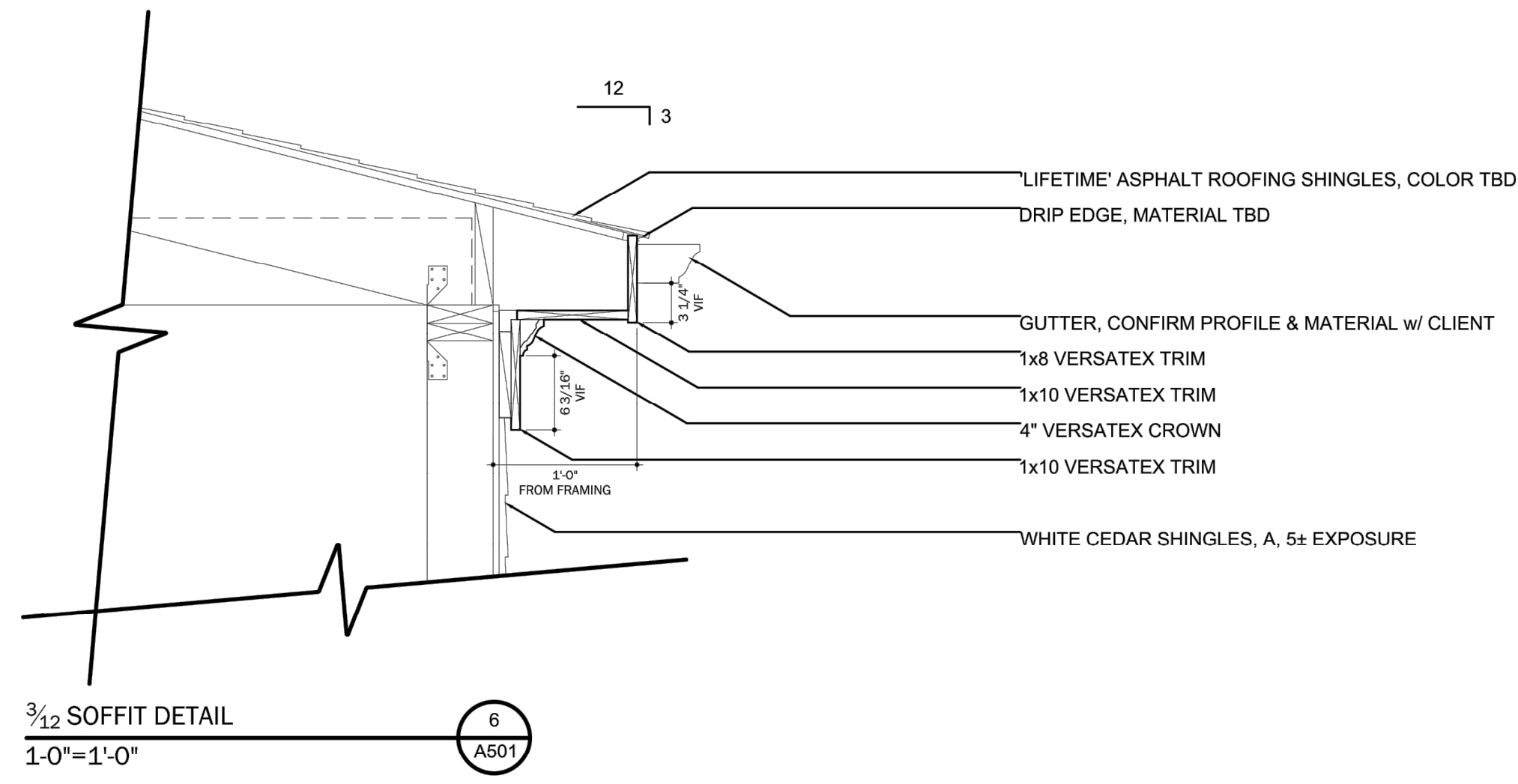
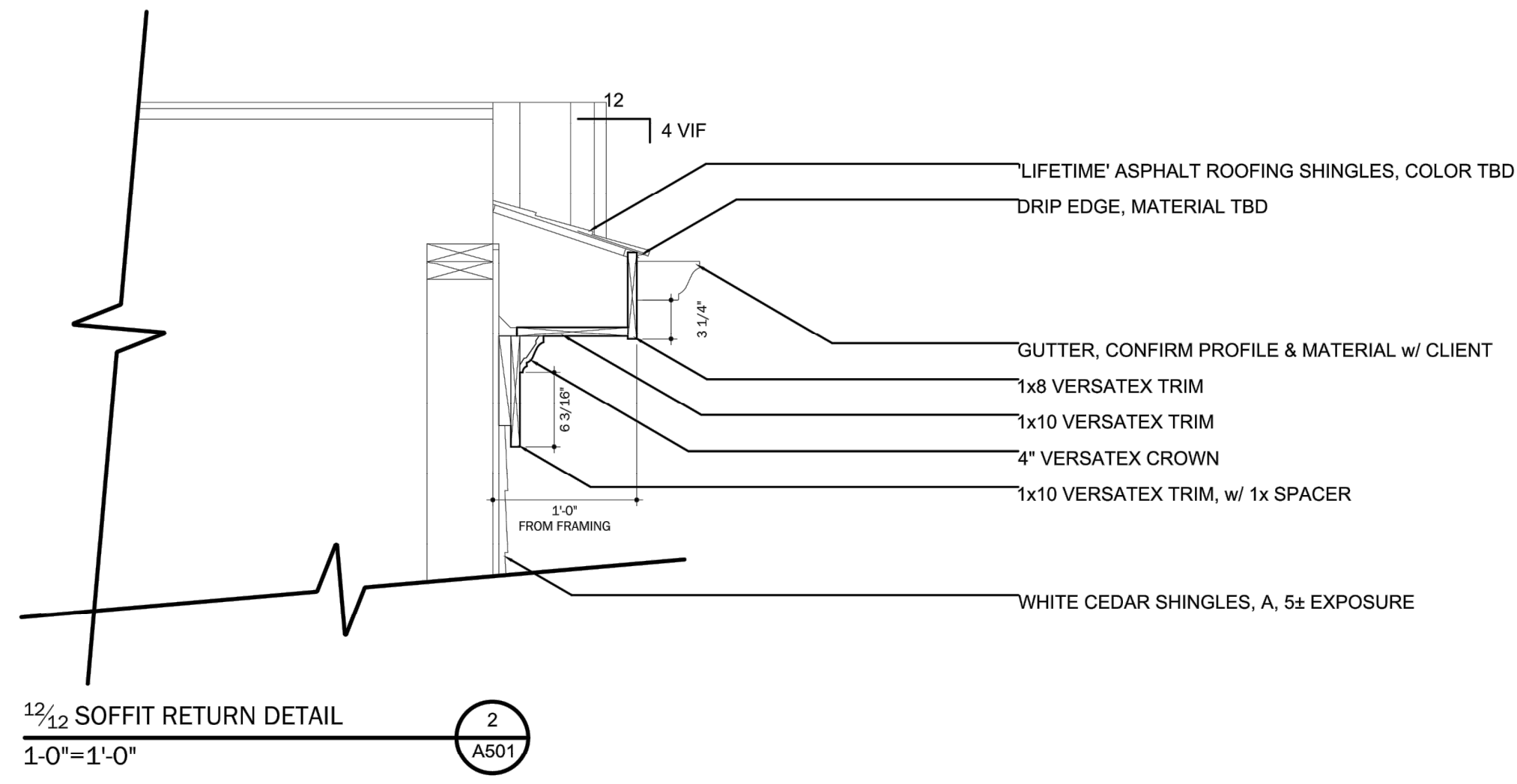
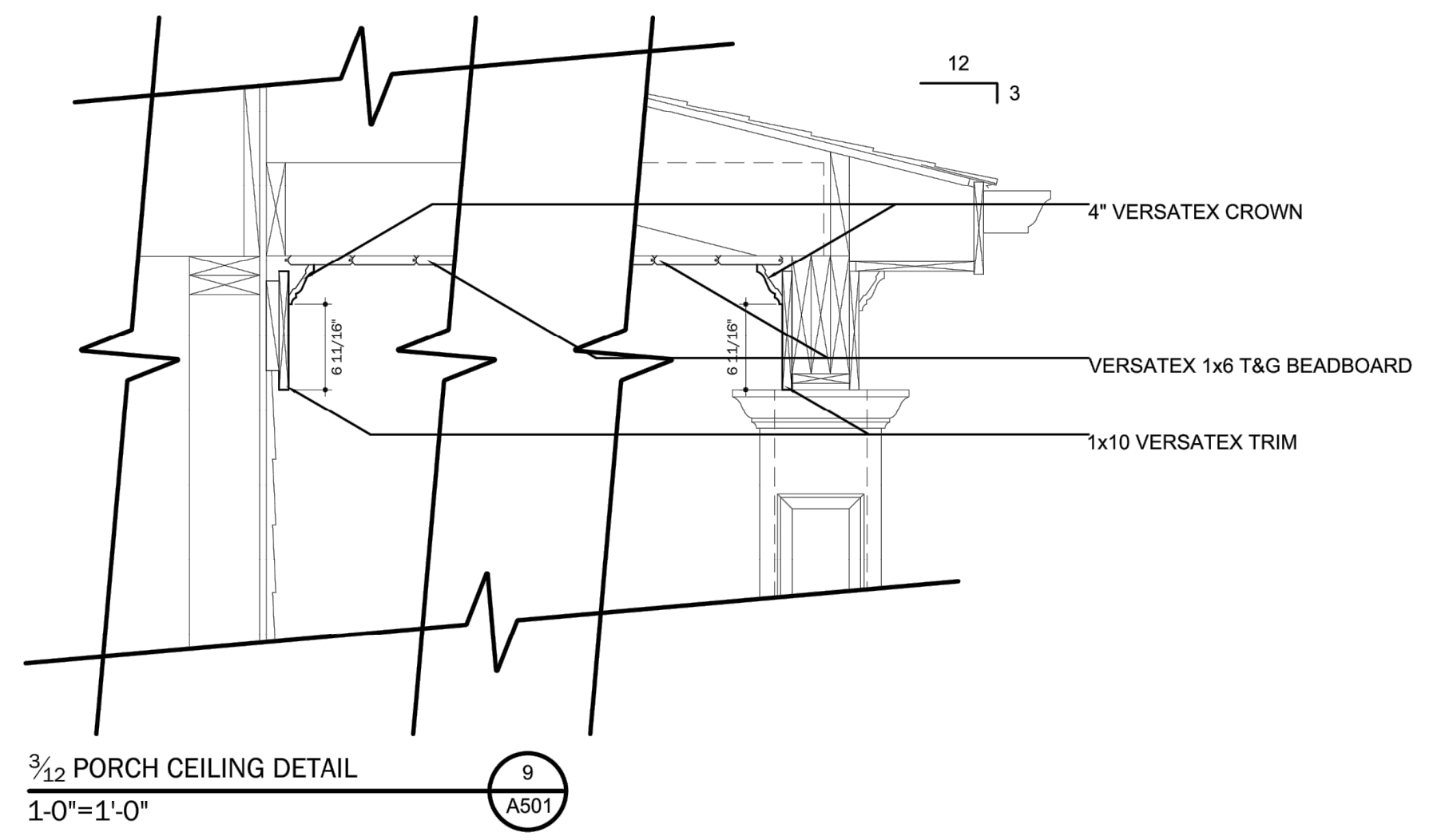
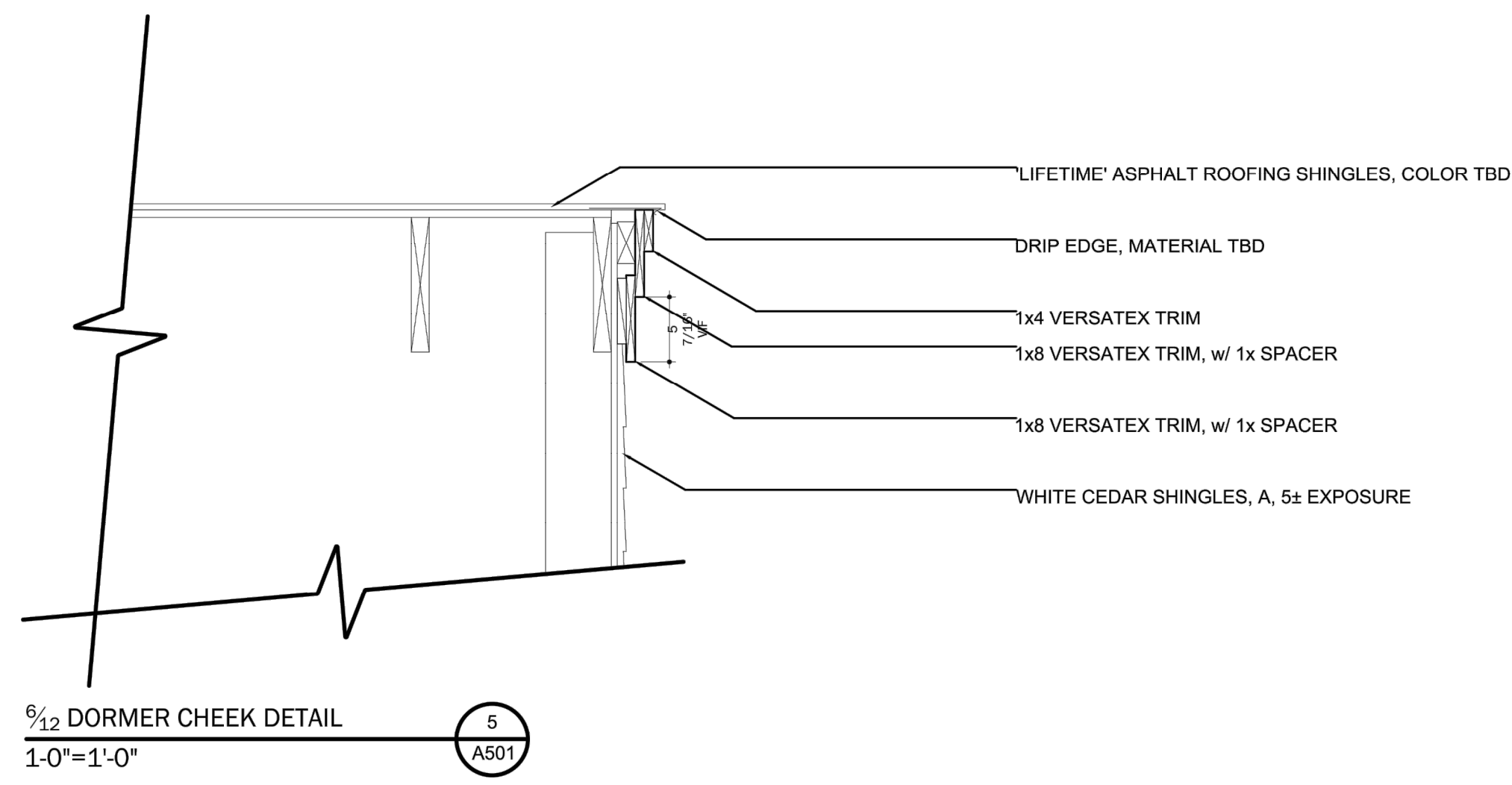
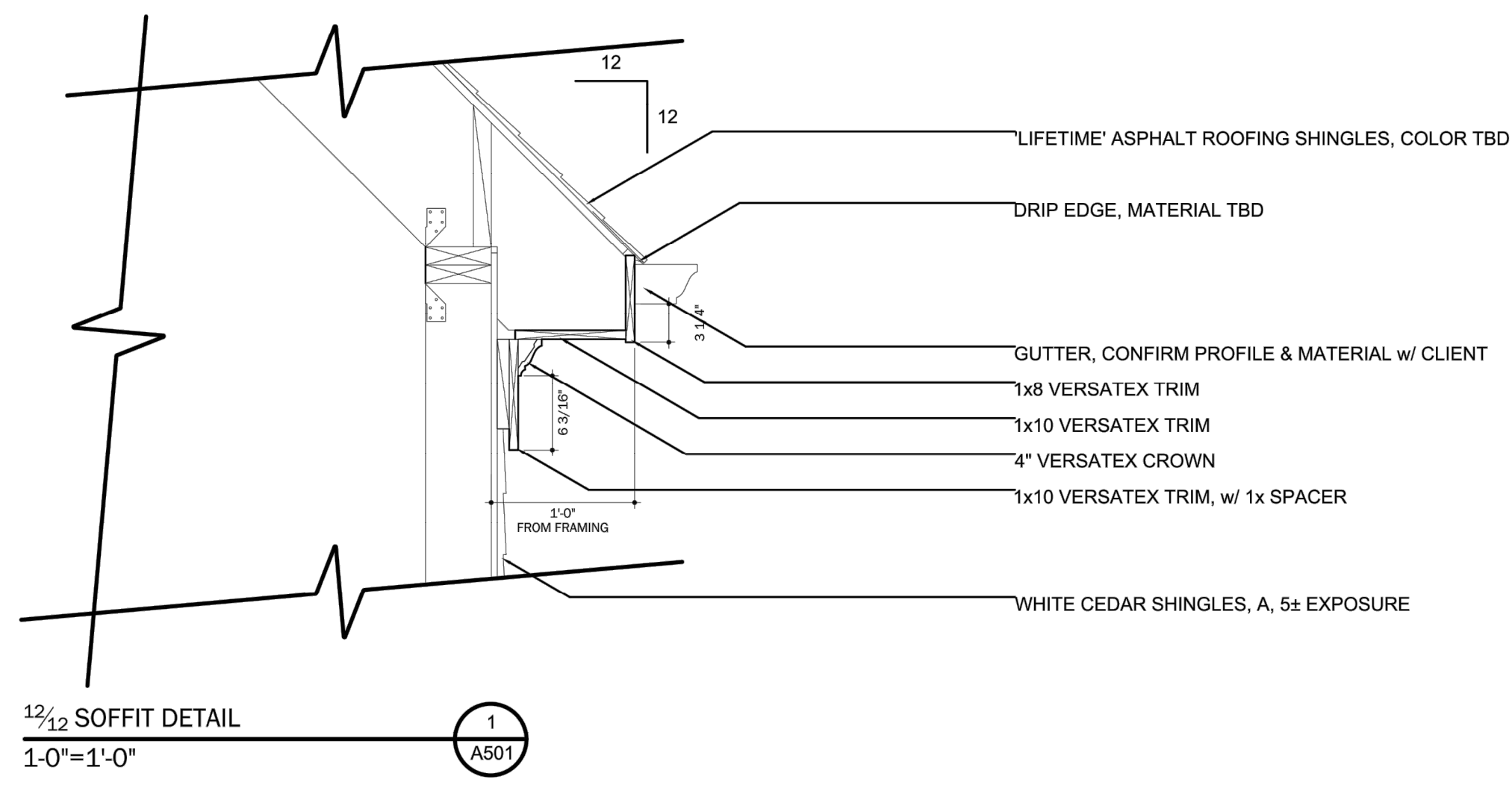

**PRICING DRAWINGS
NOT FOR CONSTRUCTION**

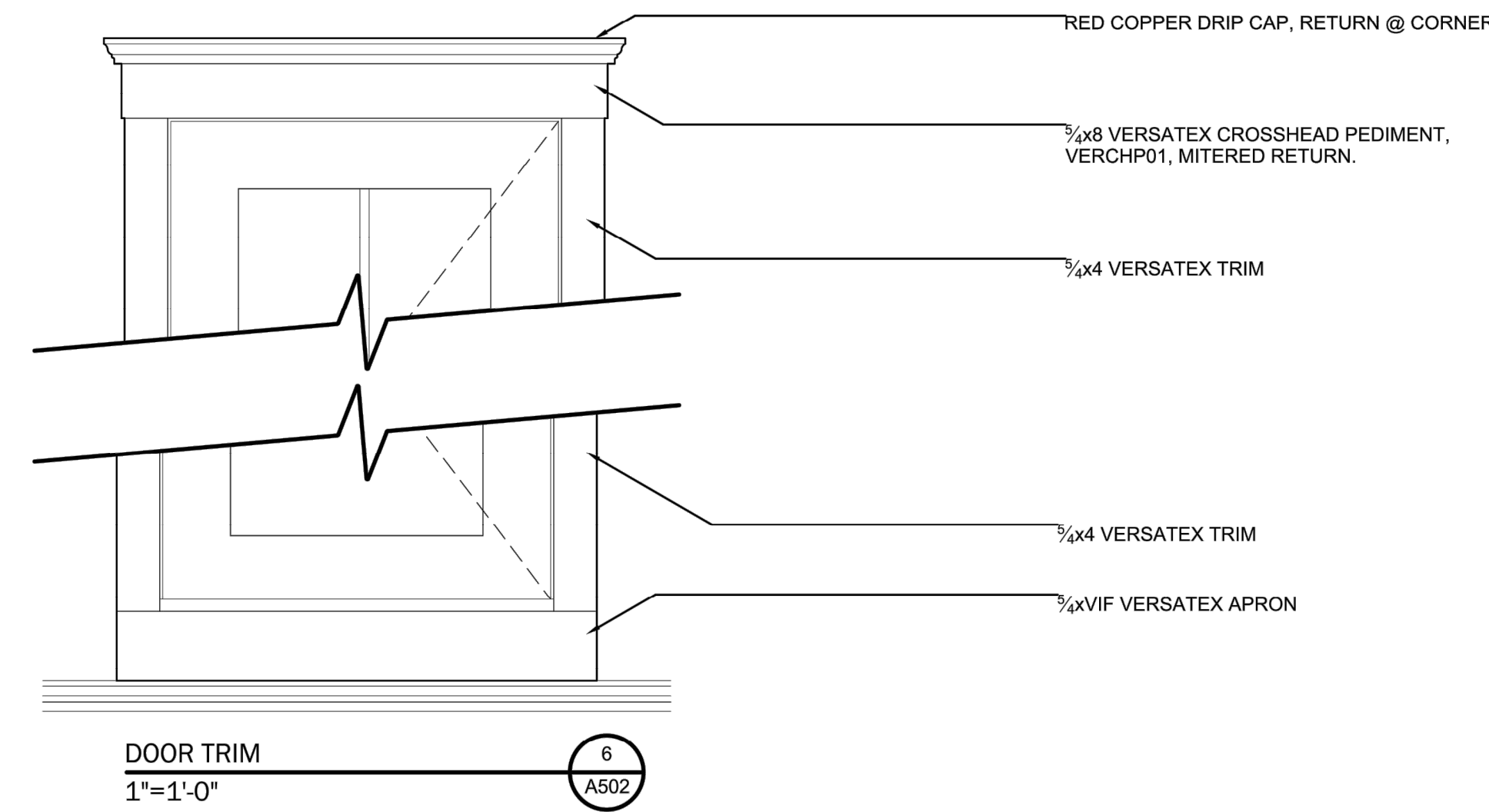
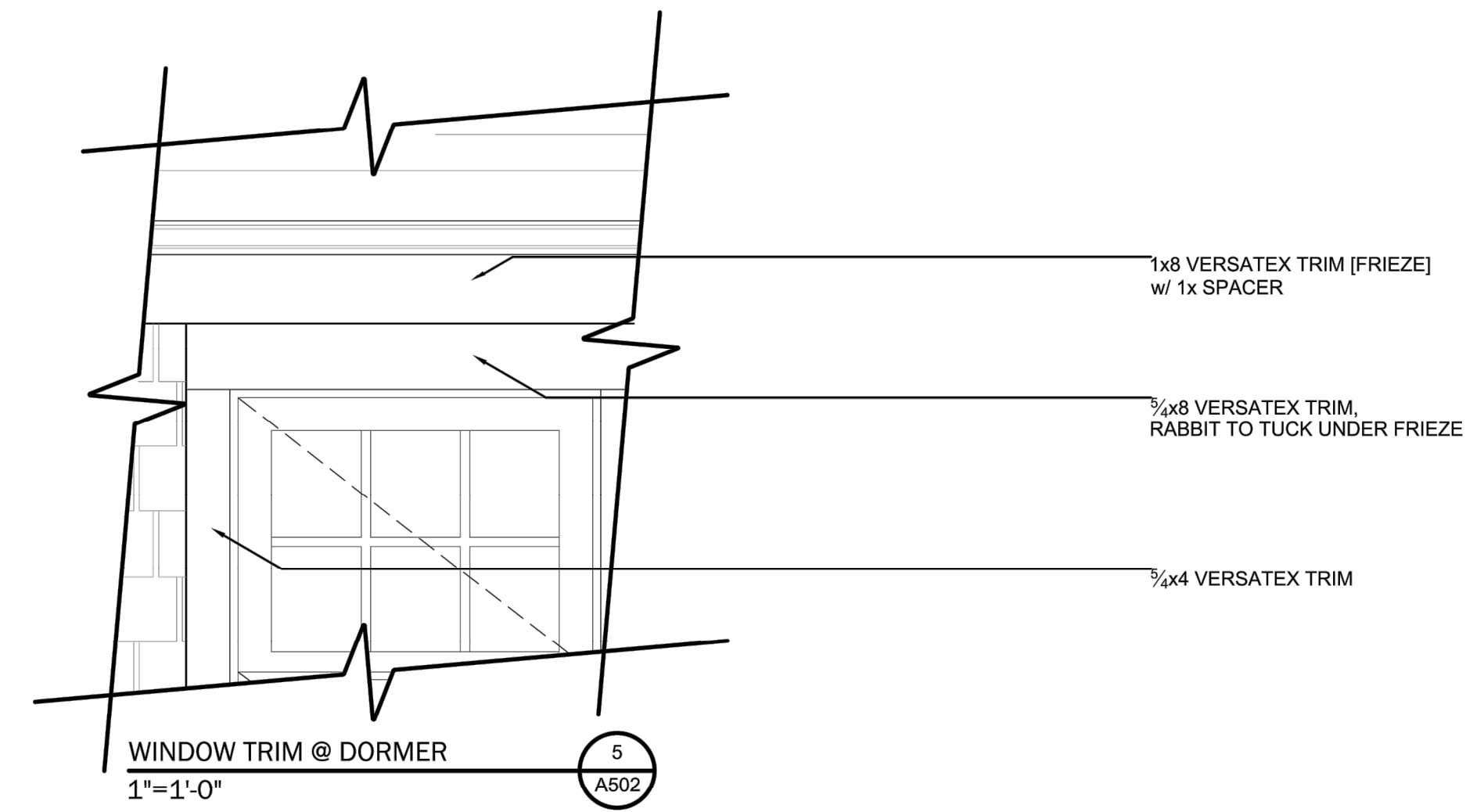
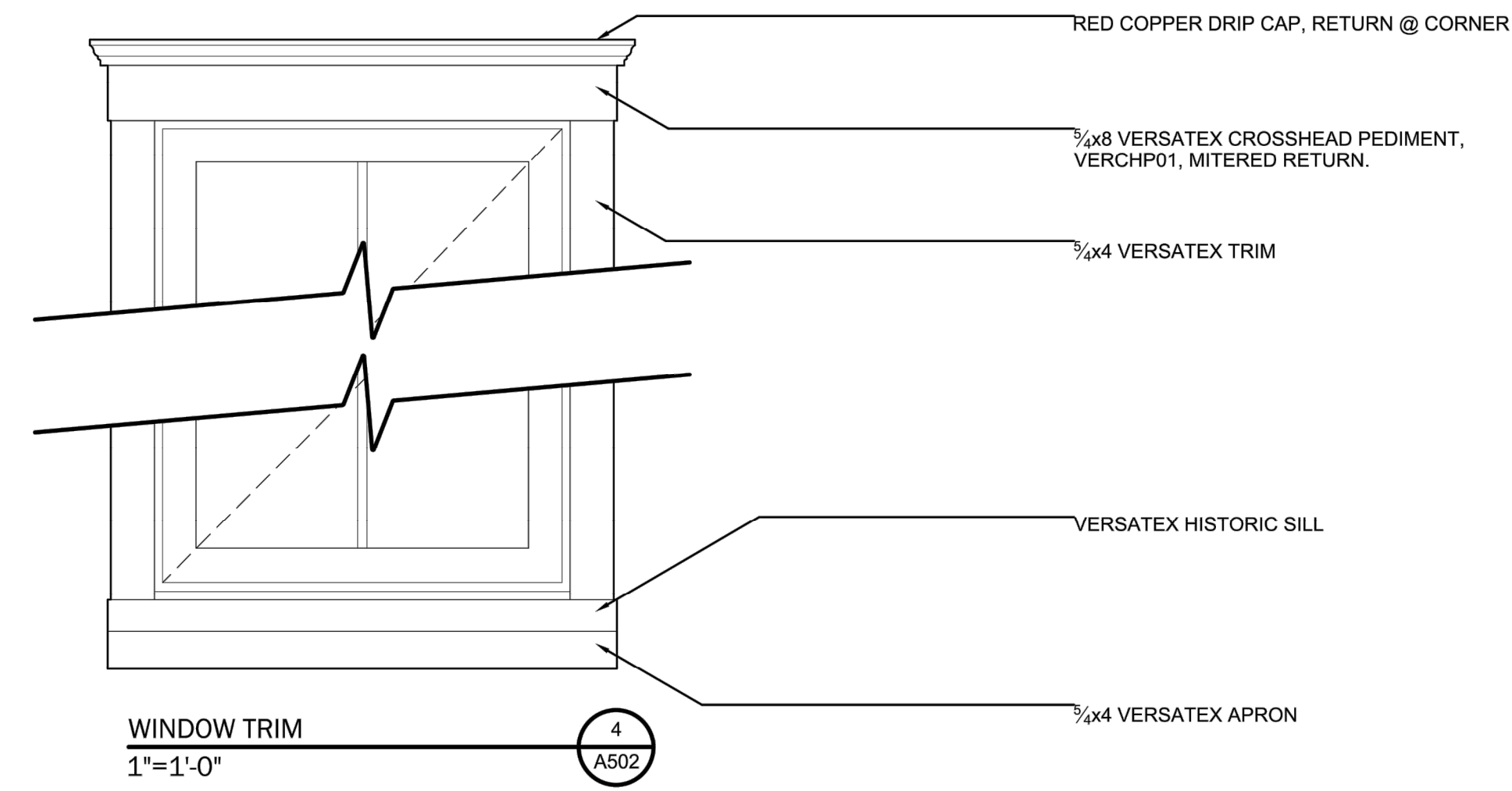
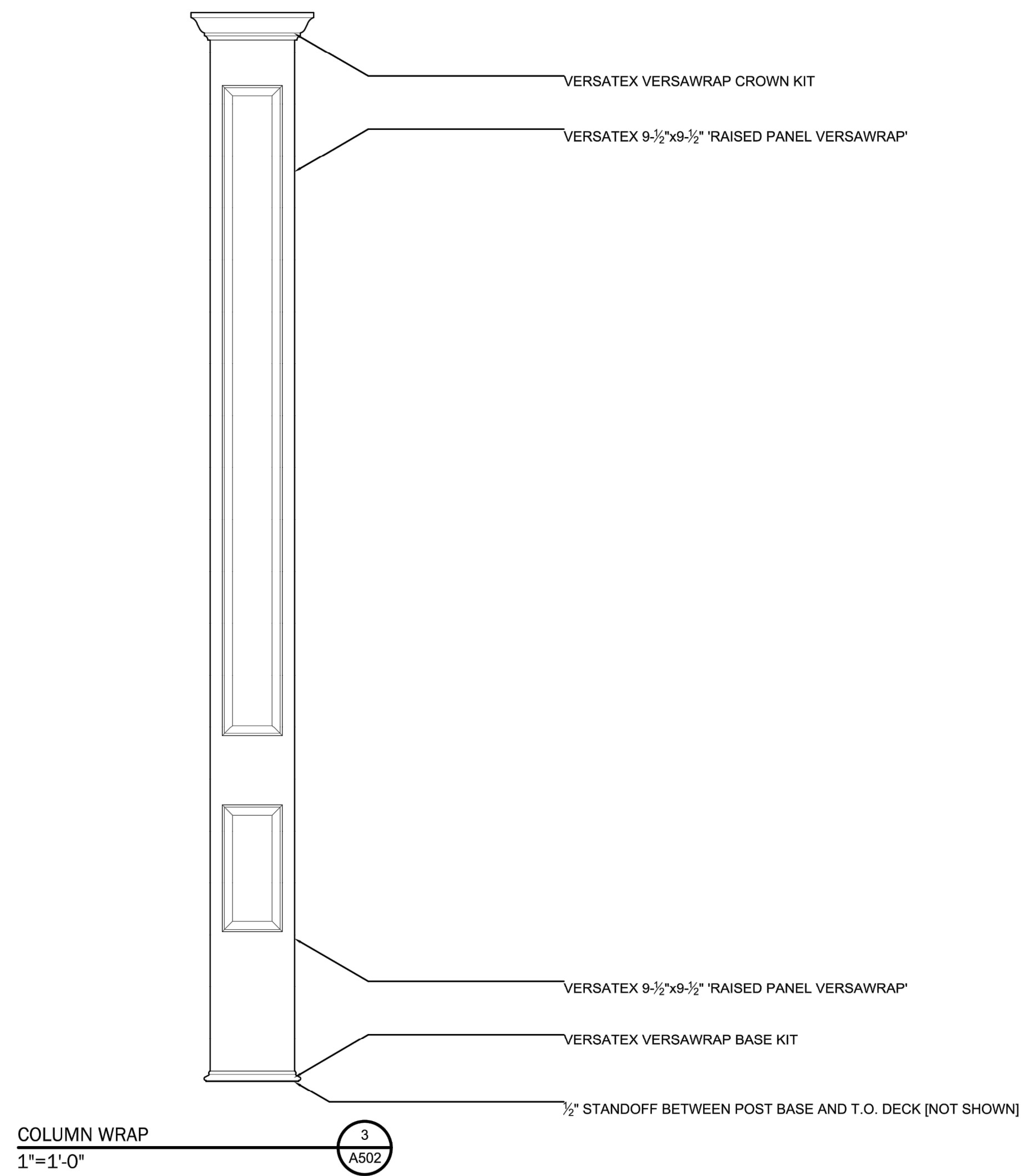
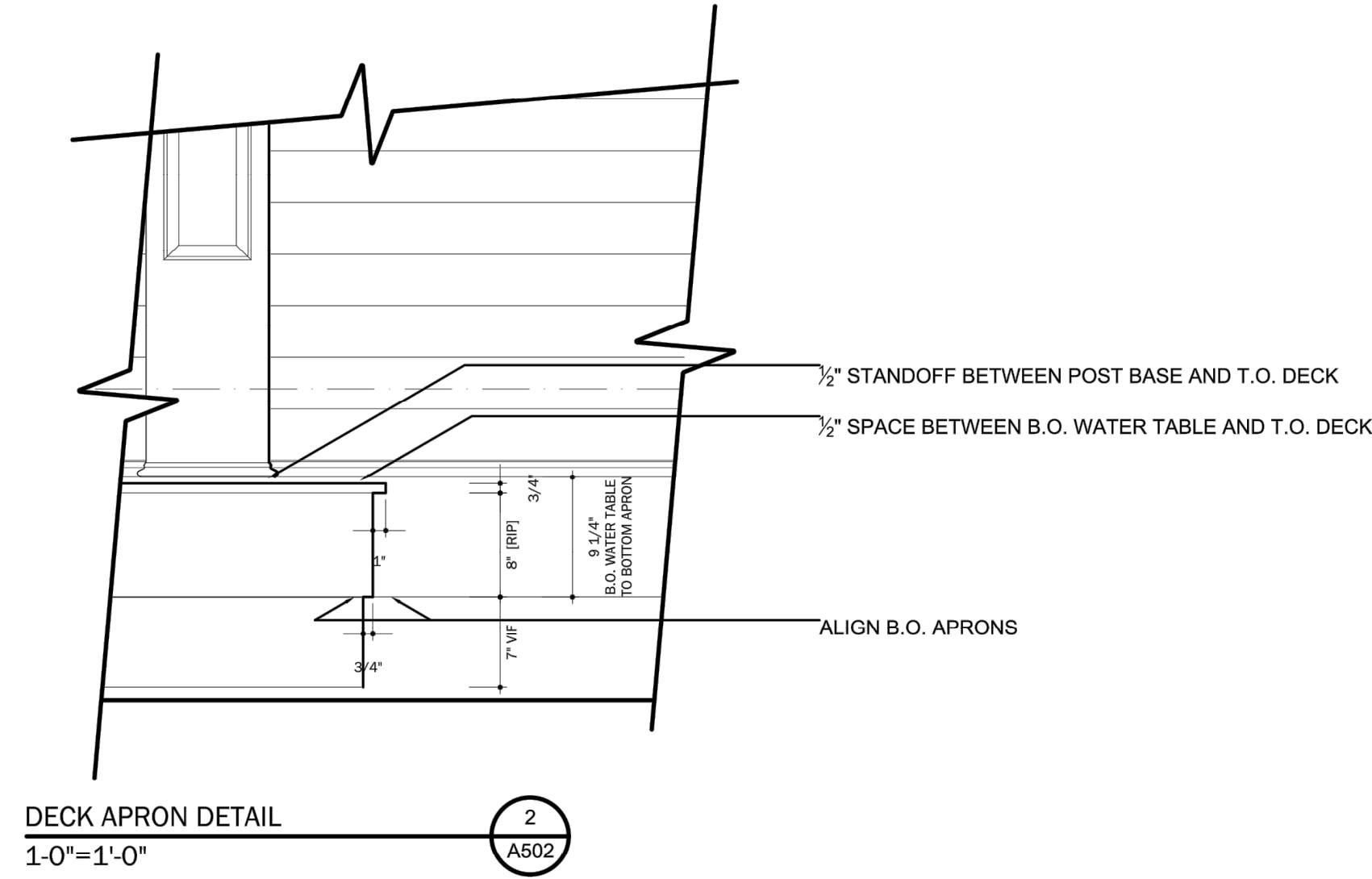
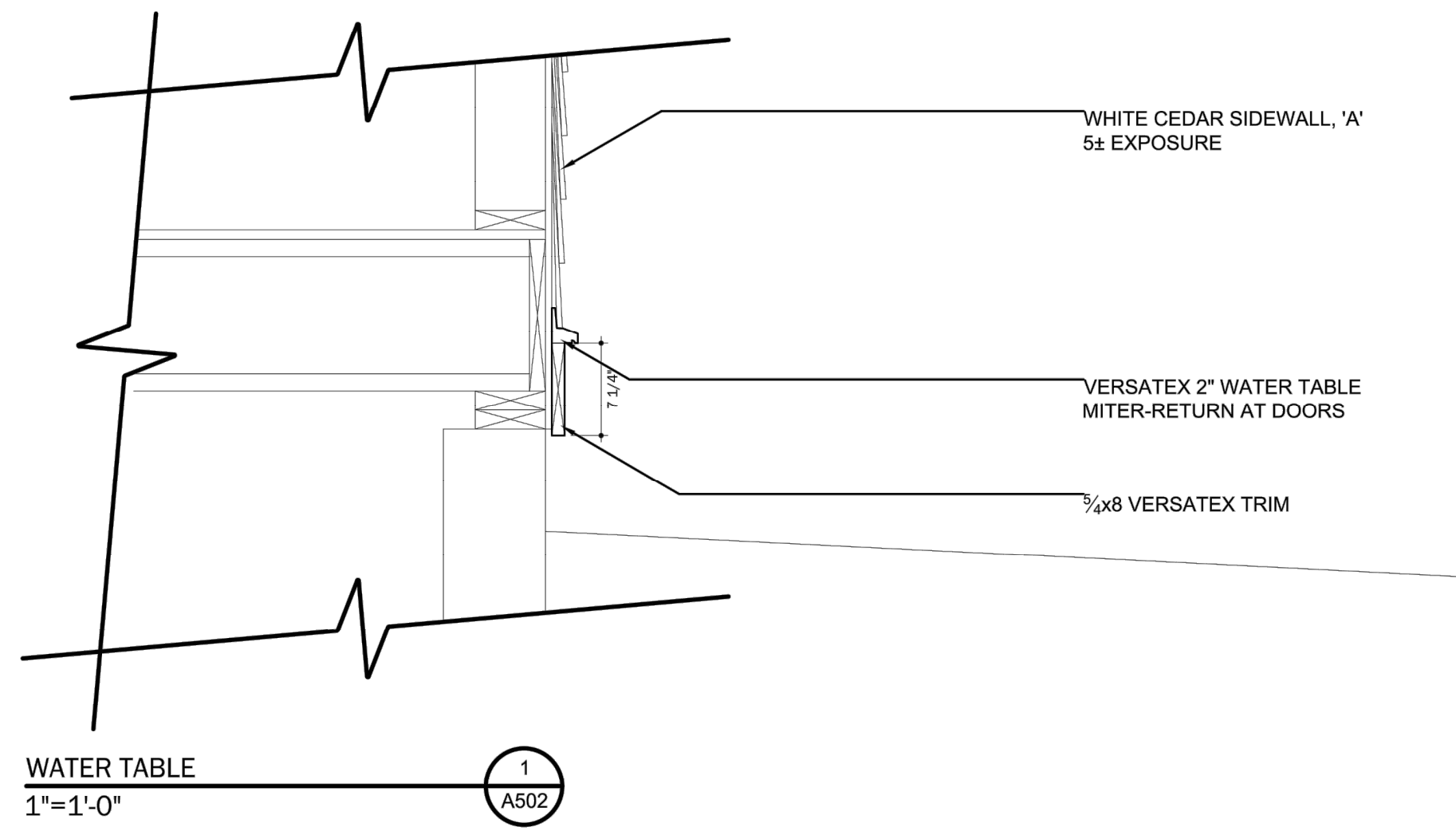

PRICING DRAWINGS
NOT FOR CONSTRUCTION

Quarters Design+Build, LLC
PO Box 2318
Vineyard Haven
MA 02568
617.671.5798
robberroche@gmail.com

CLIENT:
Mitchell & Danielle Lee
NJ

PROJECT ADDRESS
108 & 120 Pond Road
West Tisbury
MA 02575

PROJECT NO:
Q21114
PROJECT:
Lee Residence

DRAWN BY:
RPR
SHEET:
Trim Details [?]

2021.11.02

A

502

SHEET 17 OF 21

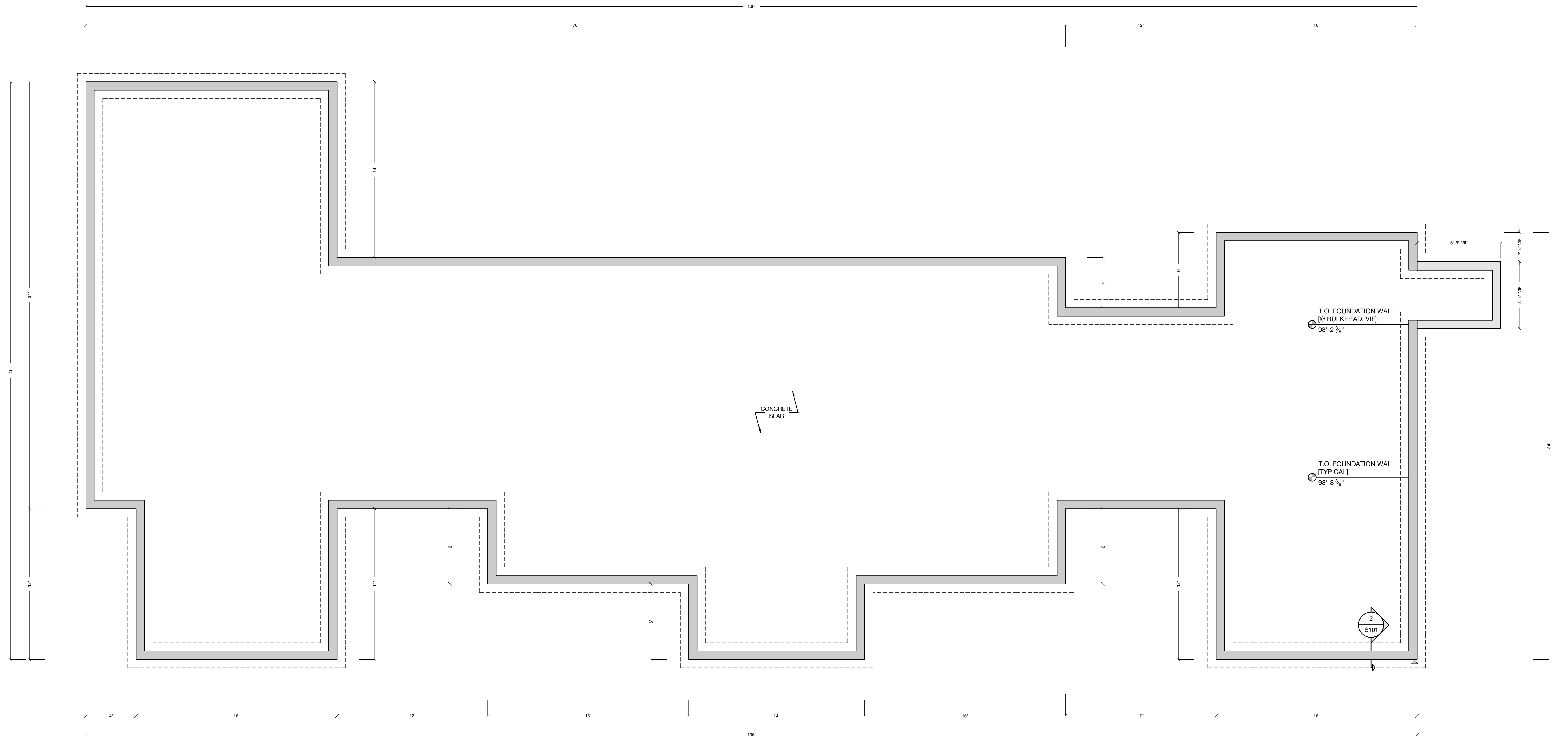

FOUNDATION PLAN
 $\frac{1}{4}'' = 1'-0''$

1
 S101

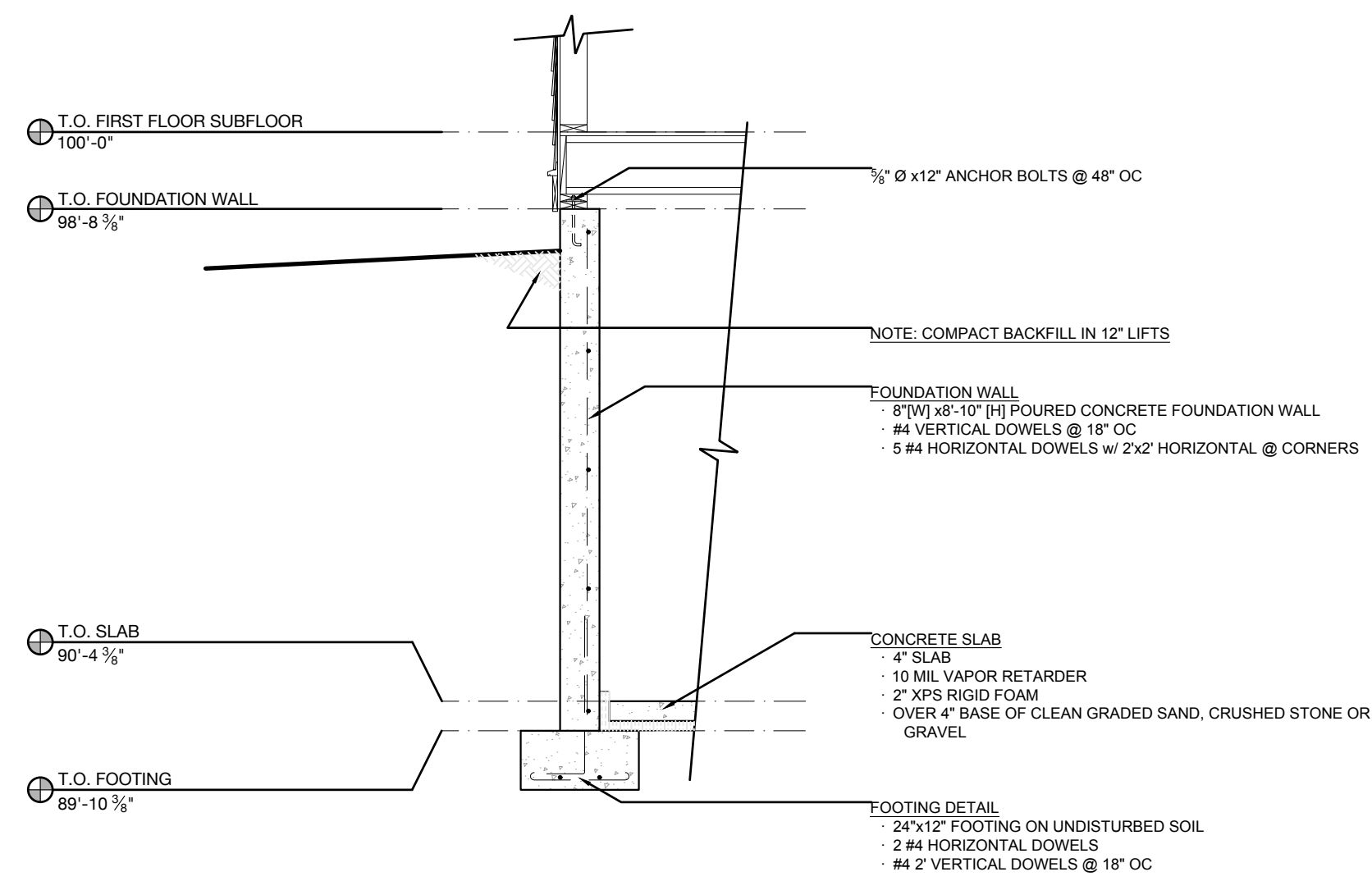

FOUNDATION WALL DETAIL
 $\frac{3}{8}'' = 1'-0''$

2
 S101

**PRICING DRAWINGS
 NOT FOR CONSTRUCTION**

Quarters Design+Build, LLC
 P.O. Box 2318
 Vineyard Haven
 MA 02568
 617.671.5738
 robppierroche@gmail.com

CLIENT:
 Mitchell & Danielle Lee
 NJ

PROJECT ADDRESS
 108 & 120 Pond Road
 West Tisbury
 MA 02575

PROJECT NO:
 Q21114
 PROJECT:
 Lee Residence

DRAWN BY:
 RPR
 SHEET:
 Foundation Plan

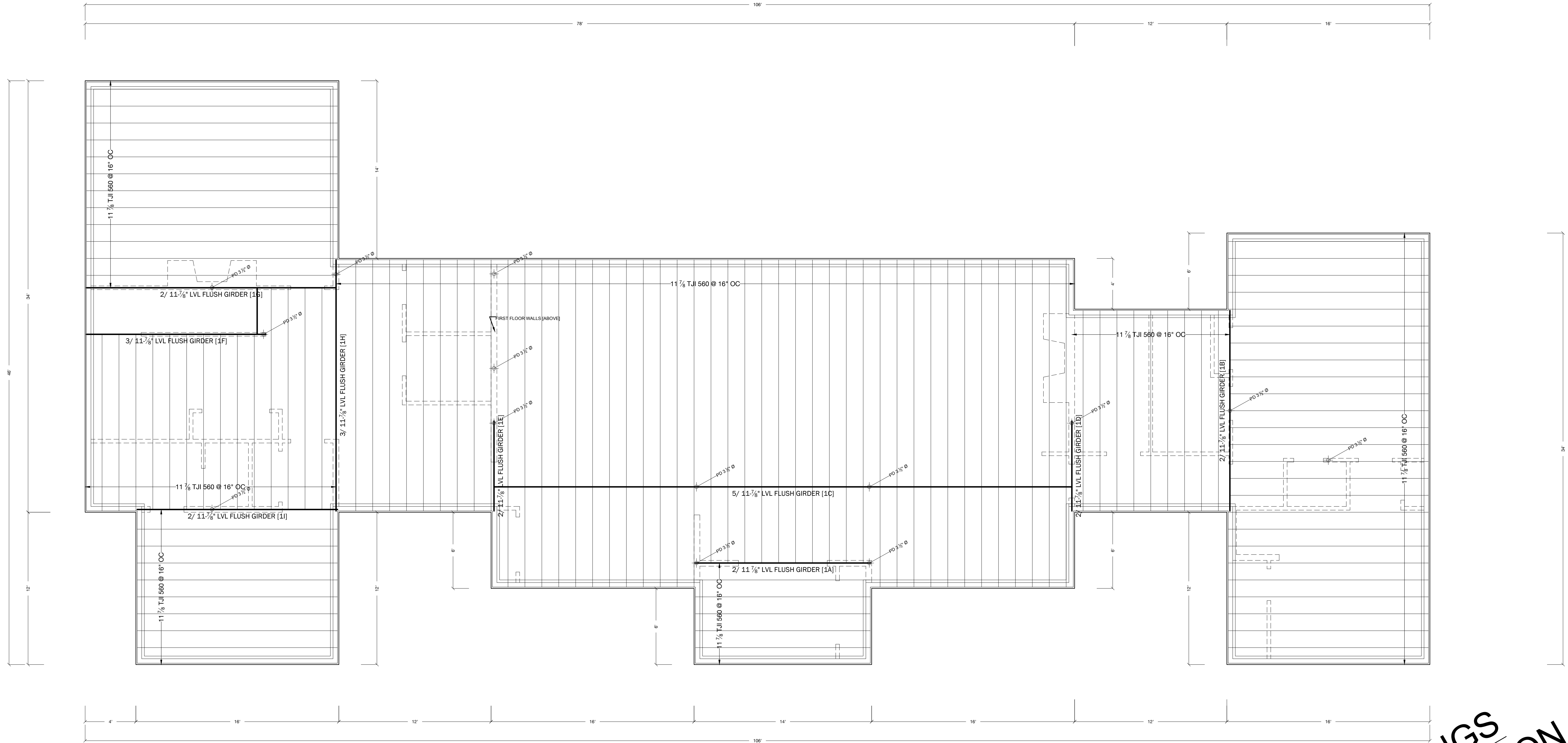

FIRST FLOOR FRAMING PLAN
 1/4" = 1'-0"

1
 S102

**PRICING DRAWINGS
 NOT FOR CONSTRUCTION**

Quarters Design+Build, LLC
 P.O. Box 2318
 Vineyard Haven
 MA 02568
 617.671.5798
 rob@quartersdesign.com

CLIENT:
 Mitchell & Danielle Lee
 NJ

PROJECT ADDRESS:
 108 & 120 Pond Road
 West Tisbury
 MA 02575

PROJECT NO.:
 Q21114
 PROJECT:
 Lee Residence

DRAWN BY:
 RPR
 SHEET:
 First Floor Framing Plan

2021.11.02

S

102

SHEET 19 OF 21

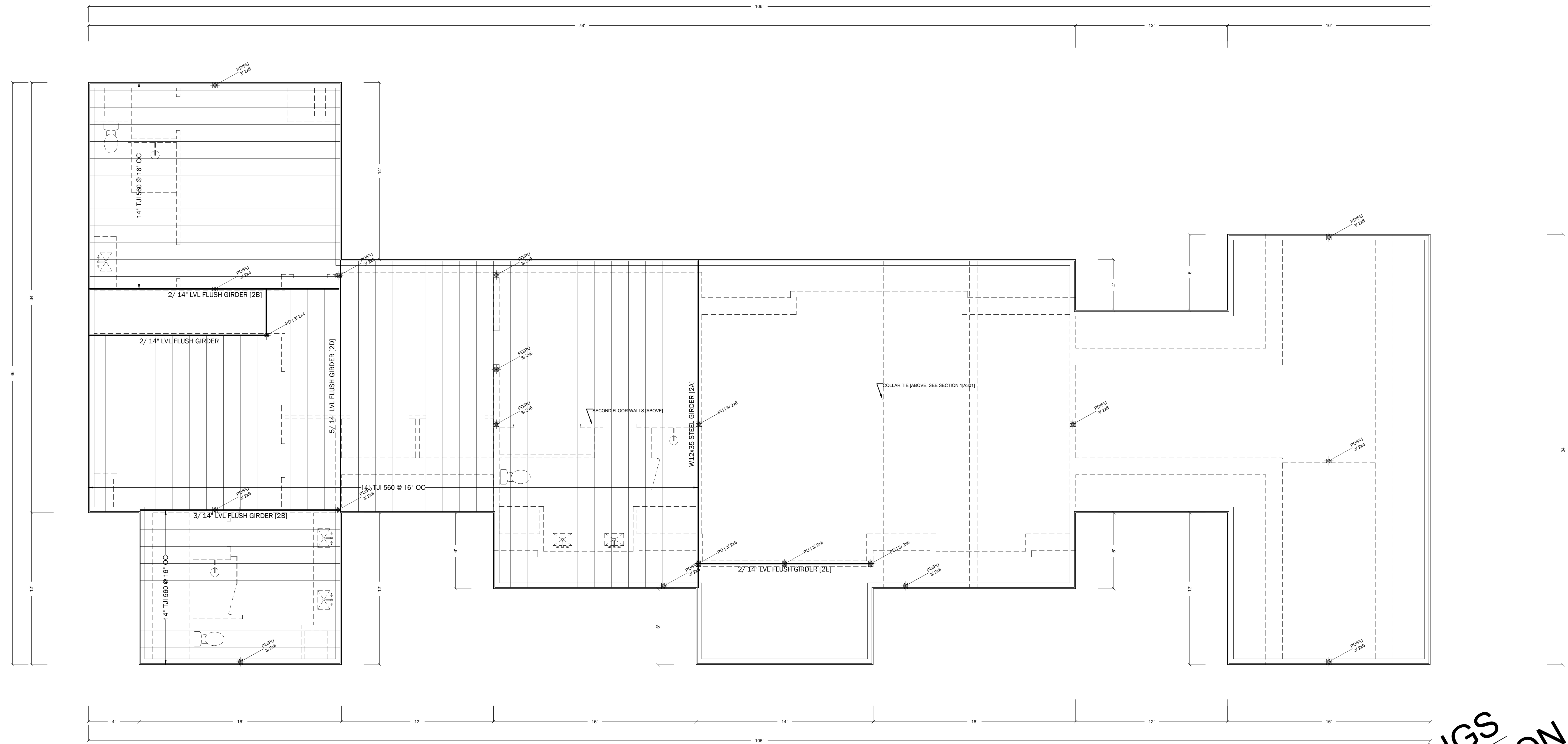

SECOND FLOOR FRAMING PLAN
 1/4" = 1'-0" 1
S103

PRICING DRAWINGS
 NOT FOR CONSTRUCTION

Quarters Design+Build, LLC
 P.O. Box 2318
 Vineyard Haven
 MA 02568
 617.671.5738
 robbperroche@gmail.com

CLIENT:
 Mitchell & Danielle Lee
 NJ

PROJECT ADDRESS:
 108 & 120 Pond Road
 West Tisbury
 MA 02575

PROJECT NO.:
 Q21114
 PROJECT:
 Lee Residence

DRAWN BY:
 RPR
 SHEET:
 Second Floor Framing Plan

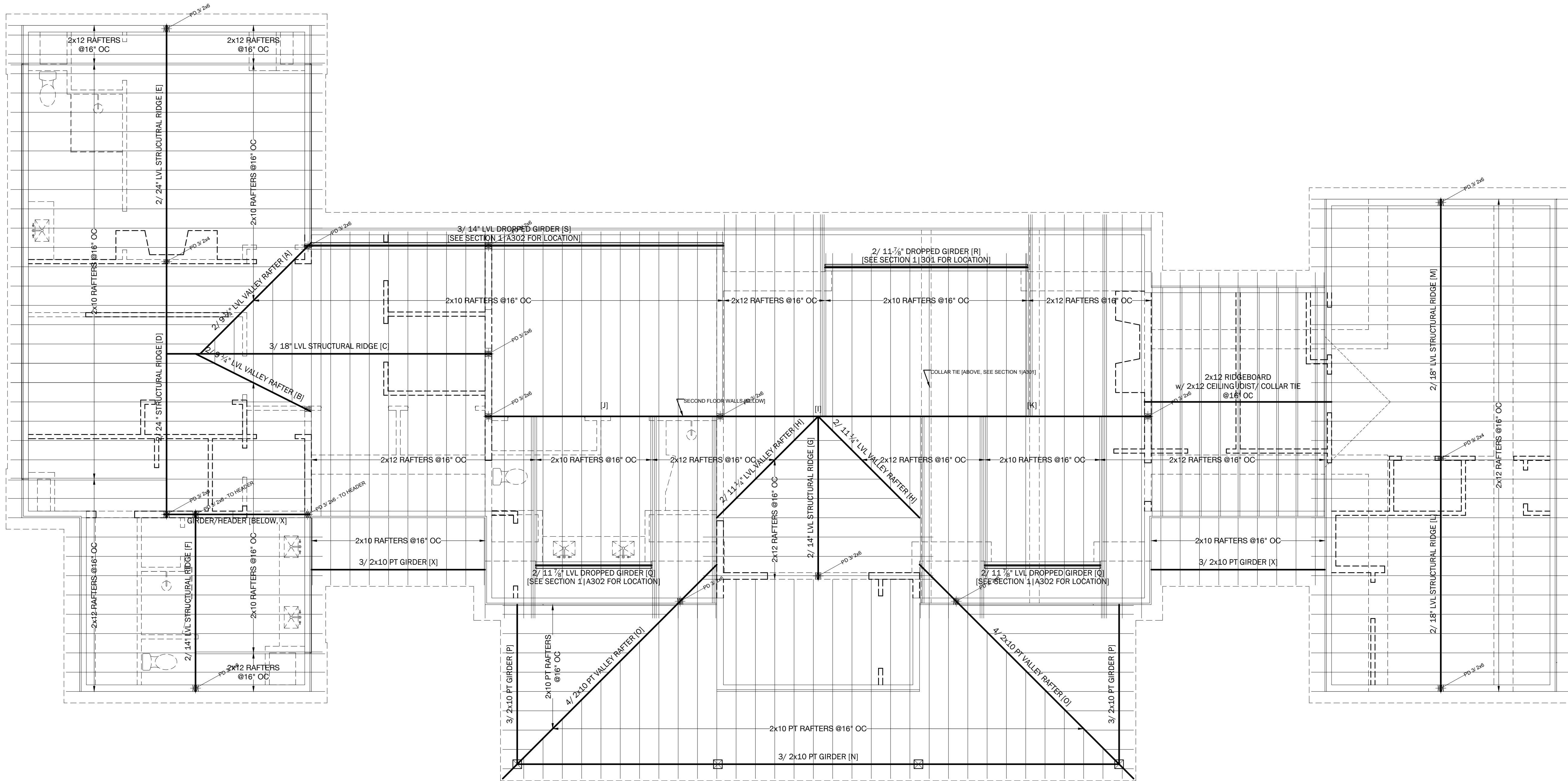

ROOF FRAMING PLAN
 1/4" = 1'-0"

**PRICING DRAWINGS
 NOT FOR CONSTRUCTION**

Quarters Design+Build, LLC
 P.O. Box 2318
 Vineyard Haven
 MA 02568
 617.671.5798
 robbiparroche@gmail.com

CLIENT:
 Mitchell & Danielle Lee
 NJ

PROJECT ADDRESS
 108 & 120 Pond Road
 West Tisbury
 MA 02575

PROJECT NO:
 Q21114
 PROJECT:
 Lee Residence

DRAWN BY:
 RPR
 SHEET:
 Roof Framing Plan

2021.11.02

S
104
 SHEET 21 OF 21