

650 Cambridge Street,
Cambridge, MA 02141
(617) 377-7800

Landscape Architect:
STIMSON
282 North Street,
Cambridge, MA 02139
(617) 876-8950

Civil Engineer:
Schofield Barini & Hoehn, Inc.
12 Surveyor's Lane,
Weymouth, MA 02588
(508) 950-2791

Structural Engineer:
Simpson Gumpertz & Heger
490 Totten Pond Road,
Waltham, MA 02451
(781) 907-0000

MEP Engineer:
Abed Consulting Engineering
251 Linton Road,
Westford, MA 01886
(978) 443-7868

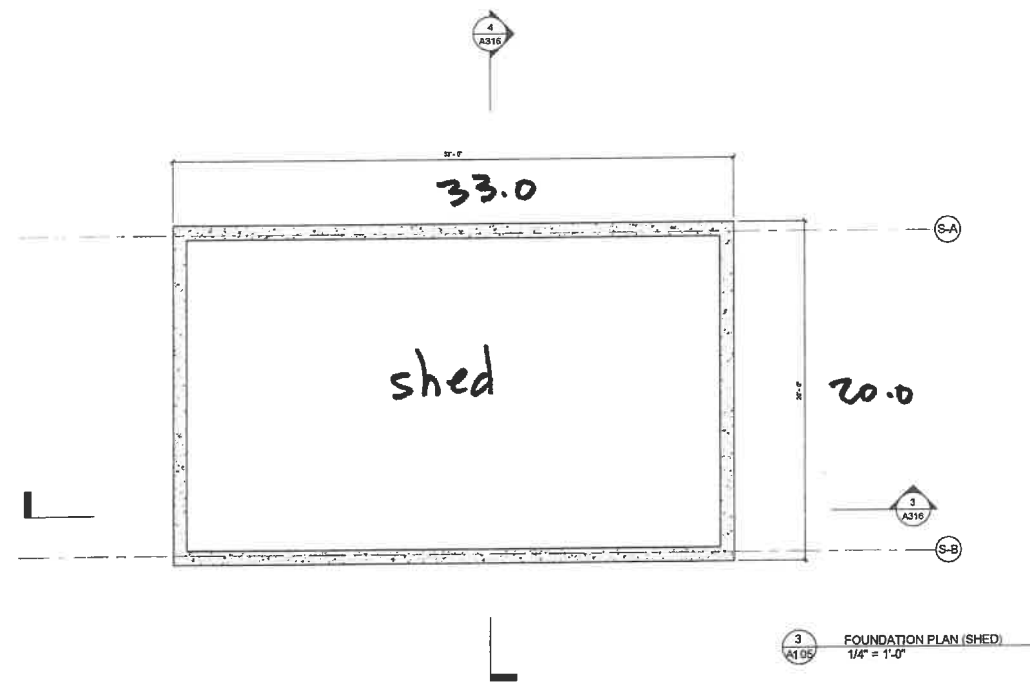
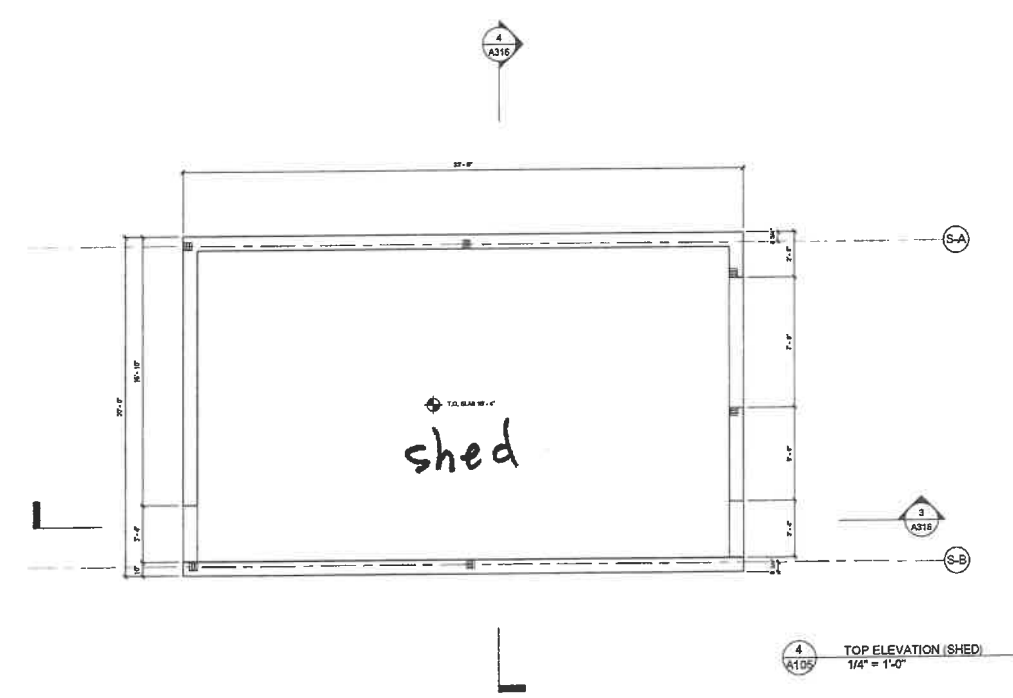
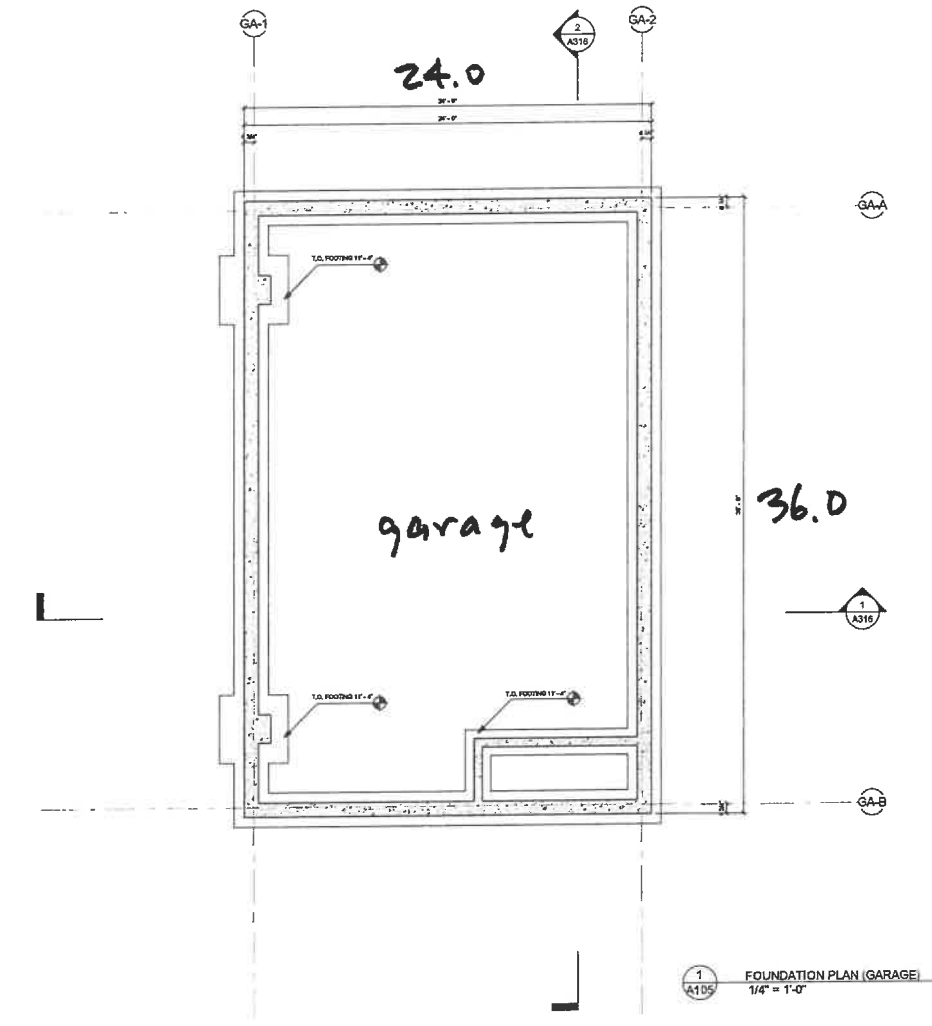
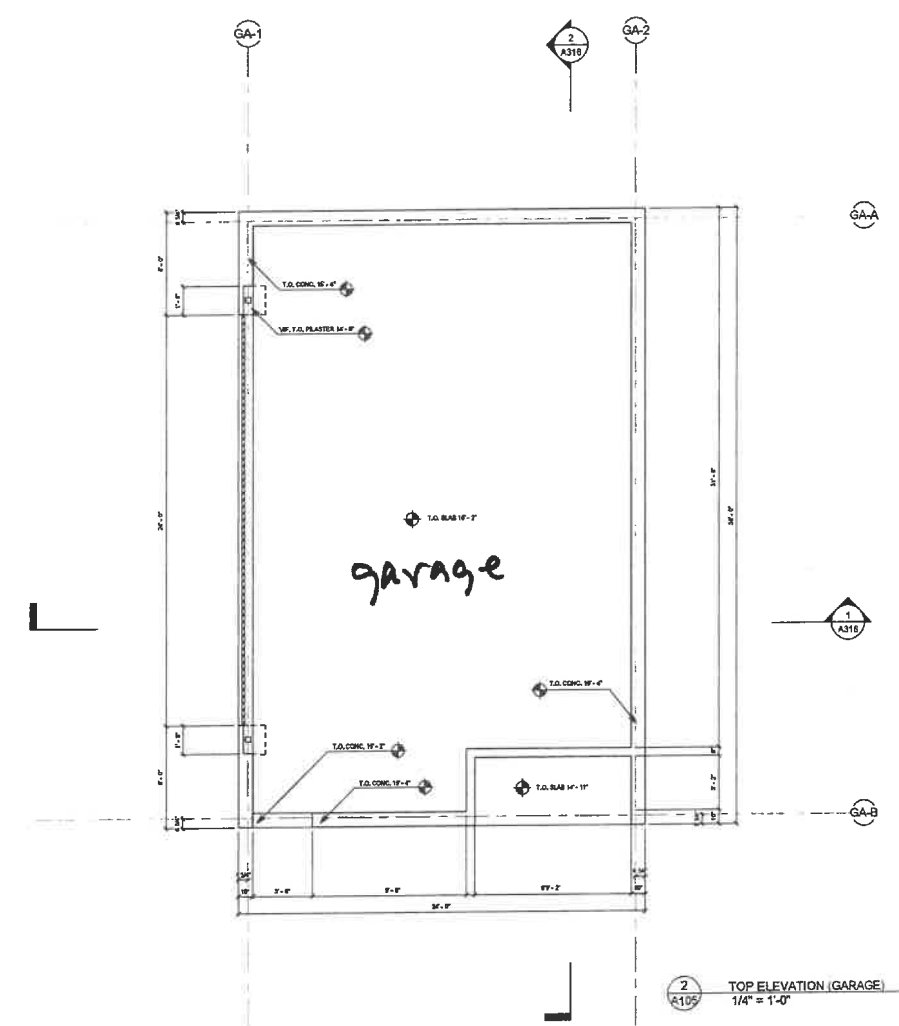

DATE	DESCRIPTION
07/25/2022	1 FOUNDATION & FRAMING SET (GARAGE ONLY)
08/01/2022	2 SPECIAL PERMIT - SHED

Agarwal Vineyard House
111 Little Horners Pond Road,
West Tisbury, MA 02575

08/01/2022
SPECIAL PERMIT - SHED

SCALE
1/4" = 1'-0"

FOUNDATION PLAN (GARAGE & SHED)

650 Cambridge Street,
Cambridge, MA 02141
(617) 577-7400

Landscape Architect:
STIMSON
290 North Street,
Cambridge, MA 02139
(617) 676-8800

Civil Engineer:
Schofield Barilini & Hoehn, Inc.
12 Surveyors Lane,
Weymouth Haven, MA 02566
(508) 663-2781

Structural Engineer:
Simpson Gumpertz & Heger
480 Totten Pond Road,
Waltham, MA 02451
(781) 907-6000

MEP Engineer:
Allied Consulting Engineering
225 Lilian Road,
Westford, MA 01586
(978) 443-7888

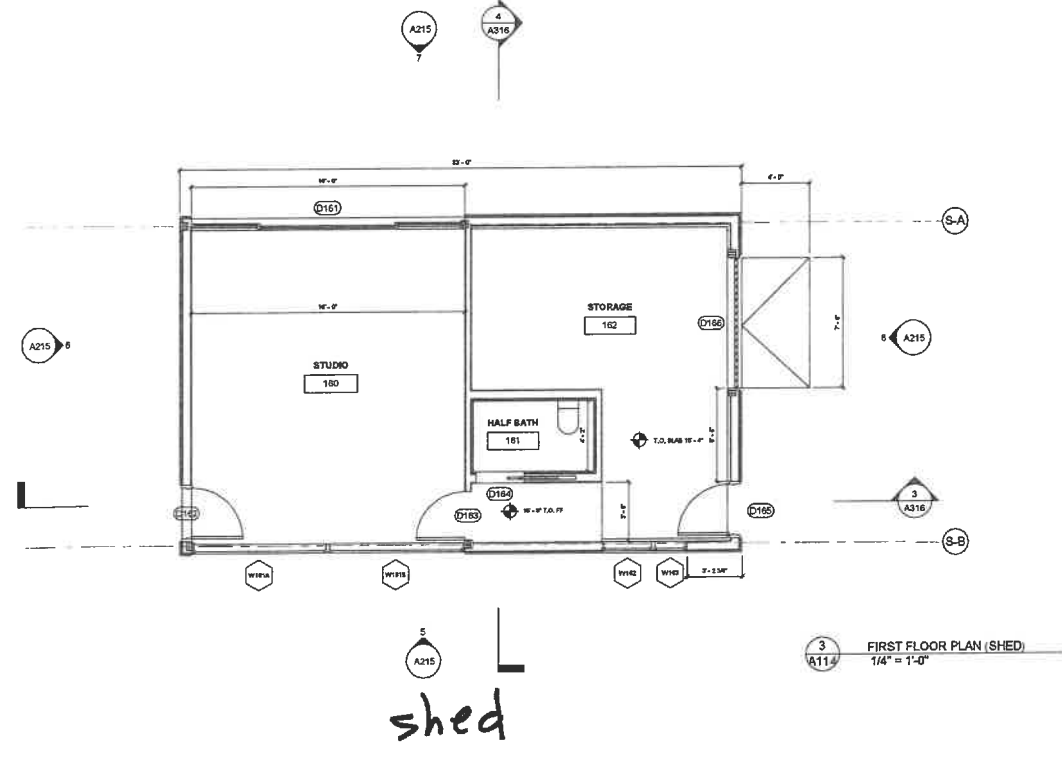
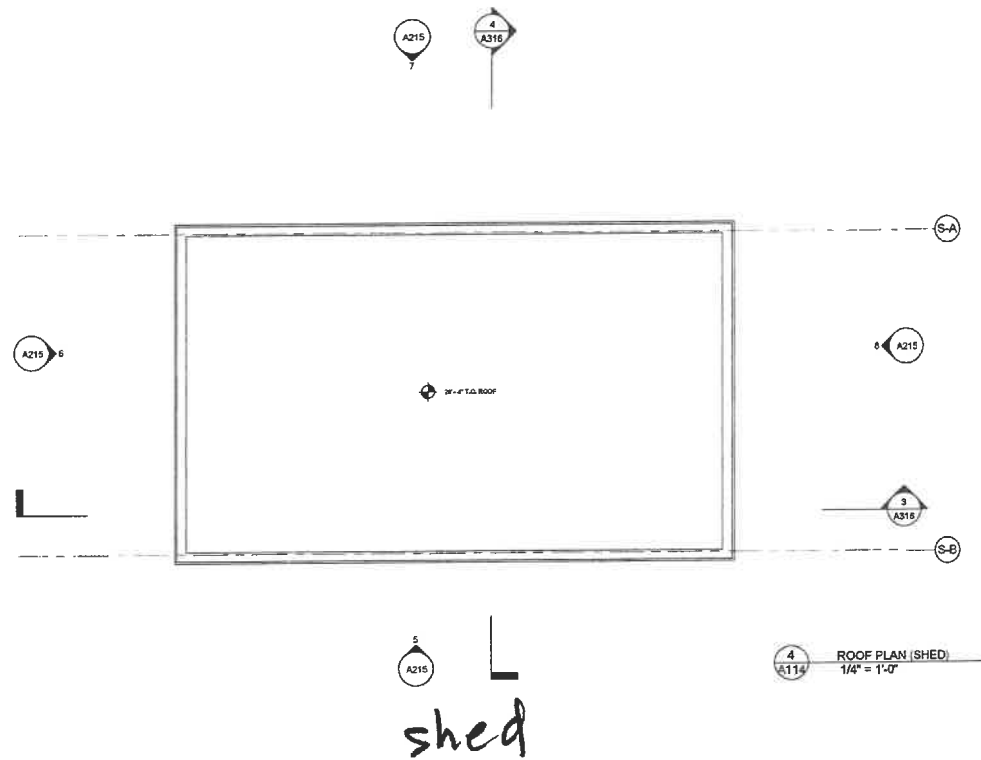
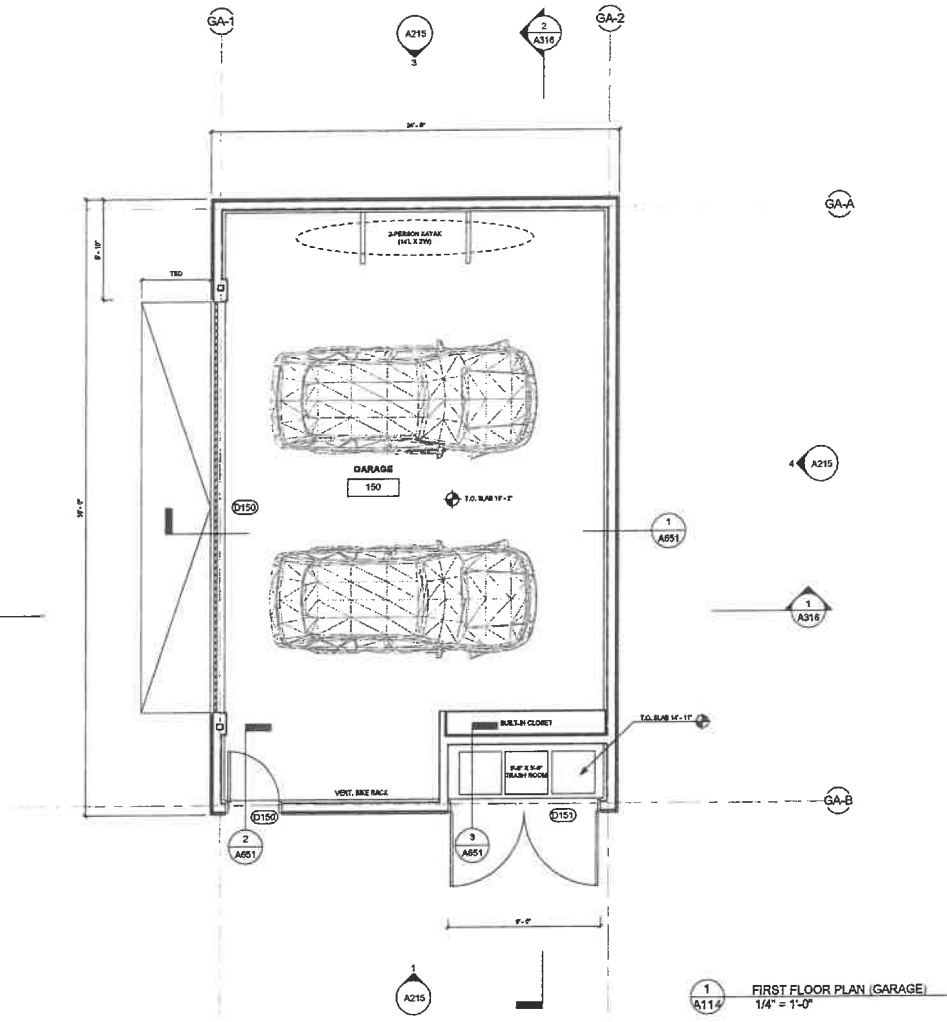
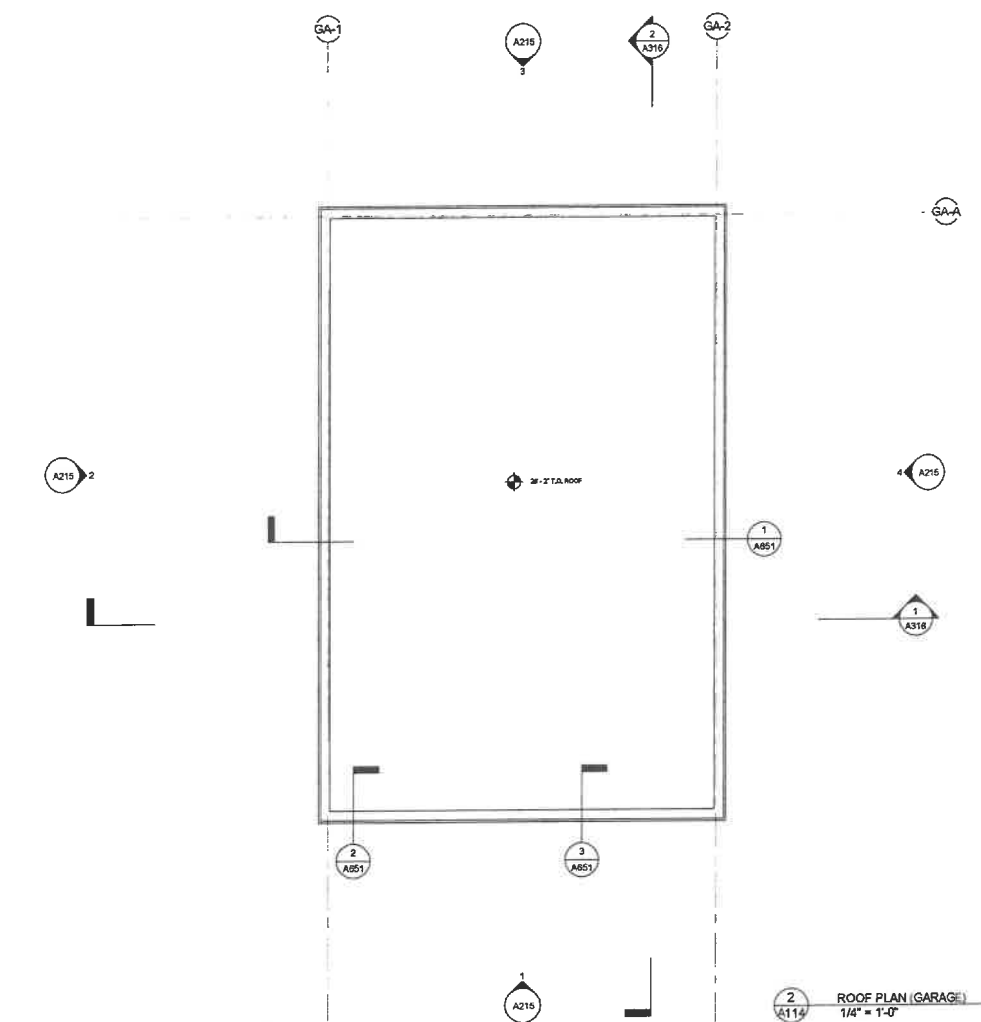

DATE	NO.	DESCRIPTION
07/25/2022	1	FOUNDATION & FRAMING SET (GARAGE ONLY)
08/01/2022	2	SPECIAL PERMIT - SHED

Agarwal Vineyard House
111 Little Homers Pond Road,
West Tisbury, MA 02575

08/01/2022
SPECIAL PERMIT - SHED

SCALE
1/4" = 1'-0"

**FIRST FLOOR PLAN,
ROOF PLAN (GARAGE &
SHED)**

A114

850 Cambridge Street,
Cambridge, MA 02141
(617) 877-7400

Landscape Architect:
STIMSON
288 North Street,
Cambridge, MA 02138
(617) 876-8660

Civil Engineer:
Scholfield Barabini & Hoehn, Inc.
17 Sargeant's Lane,
Vineyard Haven, MA 02553
(508) 893-2781

Structural Engineer:
Simpson Gumpertz & Heger
400 Totten Pond Road,
Waltham, MA 02451
(781) 907-9000

MEP Engineer:
Alfred Consulting Engineering
235 Liberty Road,
Westford, MA 01886
(978) 443-7868

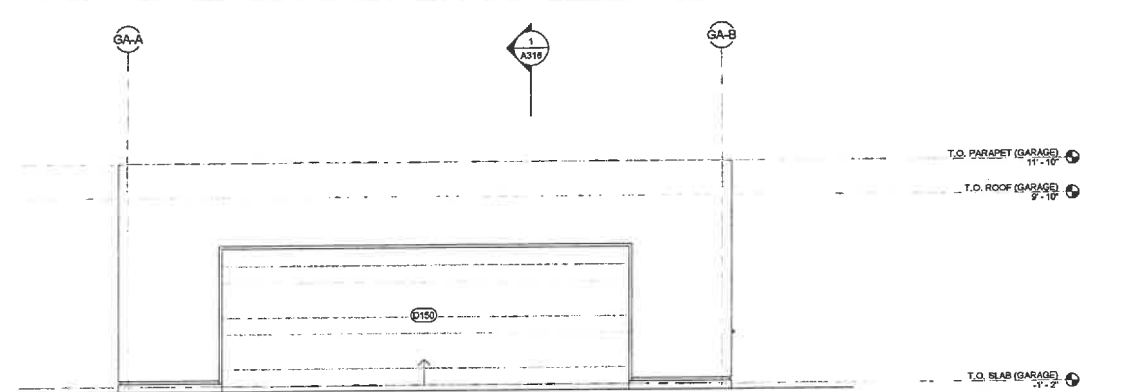

2 WEST ELEVATION (GARAGE)
1/4" = 1'-0"

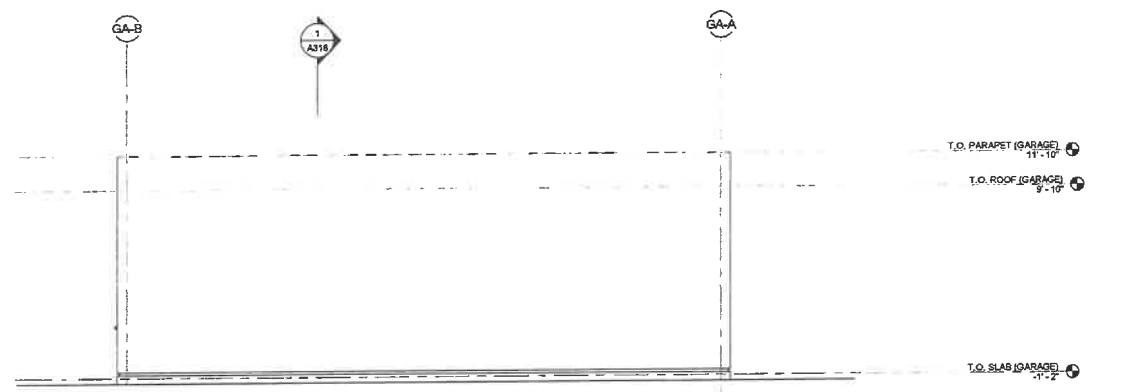

4 EAST ELEVATION (GARAGE)
1/4" = 1'-0"

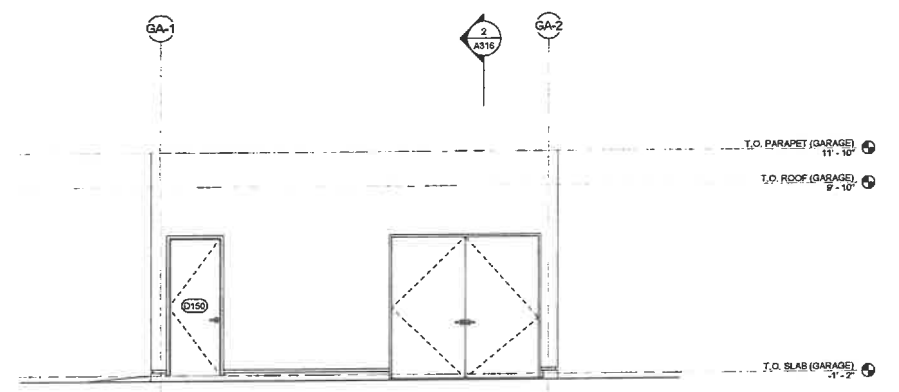

1 SOUTH ELEVATION (GARAGE)
1/4" = 1'-0"

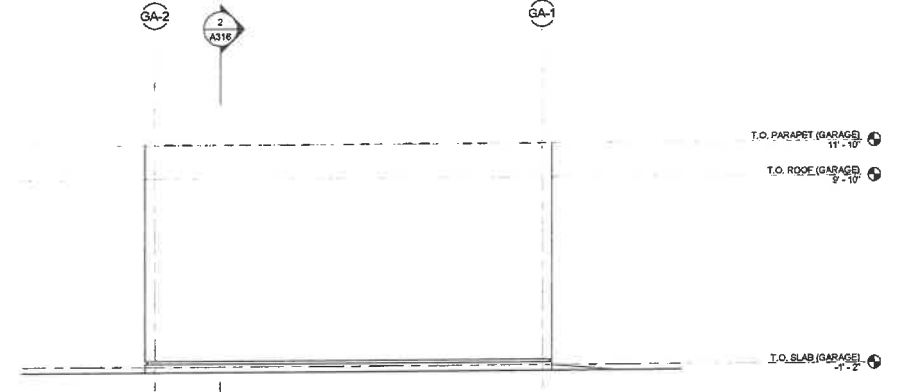

3 NORTH ELEVATION (GARAGE)
1/4" = 1'-0"

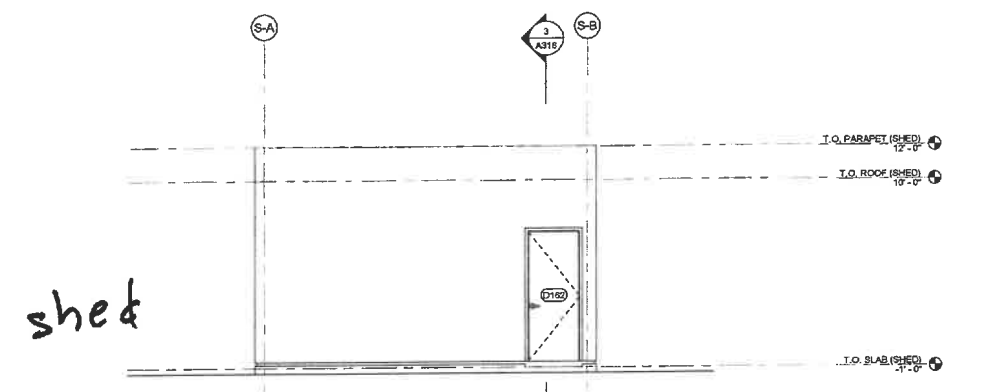

6 WEST ELEVATION (SHED)
1/4" = 1'-0"

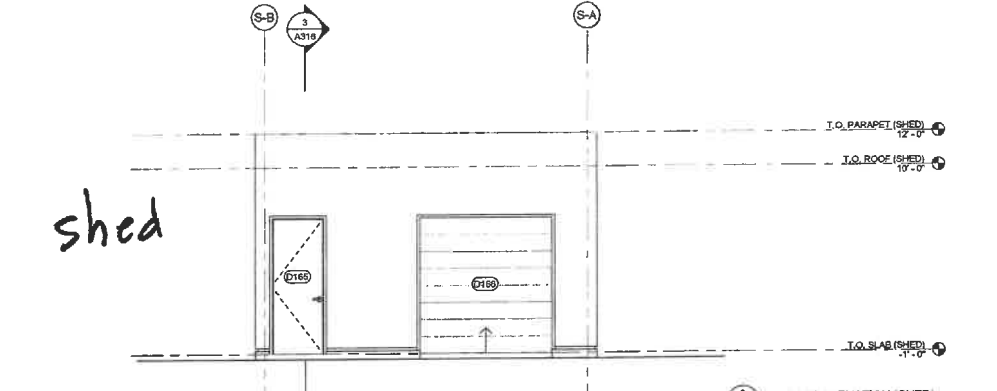

8 EAST ELEVATION (SHED)
1/4" = 1'-0"

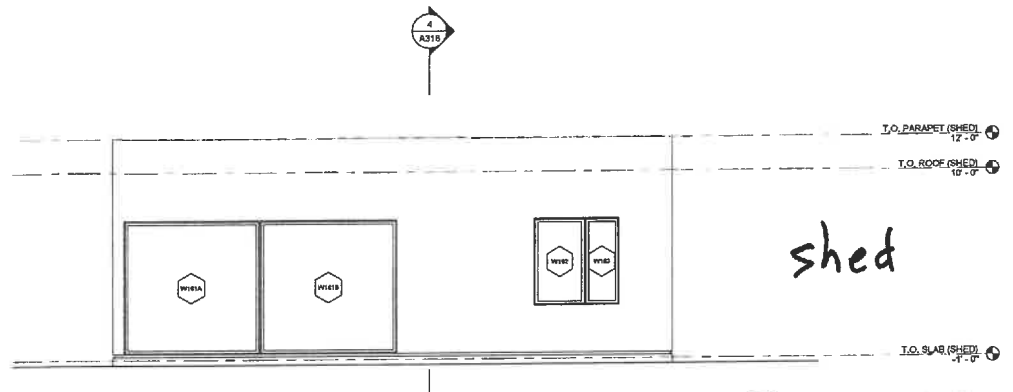

5 SOUTH ELEVATION (SHED)
1/4" = 1'-0"

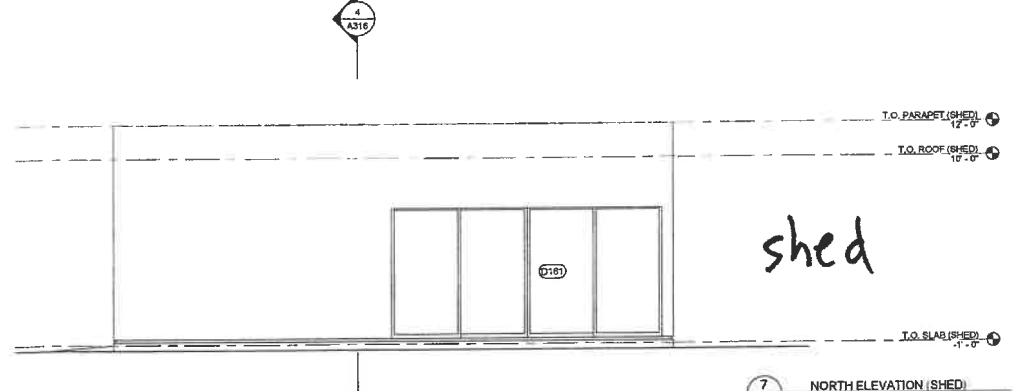

7 NORTH ELEVATION (SHED)
1/4" = 1'-0"

DATE	NO.	DESCRIPTION
07 / 25 / 2022	1	FOUNDATION & FRAMING SET (GARAGE ONLY)
08 / 01 / 2022	2	SPECIAL PERMIT - SHED

Agarwal Vineyard House
111 Little Homers Pond Road,
West Tisbury, MA 02575

DATE: 08 / 01 / 2022
SPECIAL PERMIT - SHED

SCALE: 1/4" = 1'-0"
PROJECT: BUILDING ELEVATIONS (GARAGE & SHED)

NO. A215